



FERRARI Motor mowers, FERRARI 2-wheel tractors

338 PS

03/11/2022

A30002 - 338 PS.....	4
A.01.01.A0003_01 - ENGINE PROTECTIONES.....	7
A.01.01.A0003_02 - ENGINE PROTECTIONES.....	9
A.01.01.A0003_03 - ENGINE PROTECTIONES.....	11
B.01.01.A0001_03 - POWERSAFE CLUCH CONTROL.....	13
B.01.01.A0001_04 - POWERSAFE CLUCH CONTROL.....	15
B.01.01.A0001_05 - POWERSAFE CLUCH CONTROL.....	17
B.01.01.A0001_06 - POWERSAFE CLUCH CONTROL.....	19
C01_1_72820 - CYLINDER AND POWERSAFE CLUTCH.....	21
C.01.01.A0001_02 - CYLINDER AND POWERSAFE CLUTCH.....	23
D.01.01.A0001_02 - POWERSAFE FILTER AND UNIT.....	25
D.01.01.A0001_03 - POWERSAFE FILTER AND UNIT.....	27
E01_1_132337 - POWERSAFE CLUTCH HUB.....	29
E.01.01.A0001_02 - POWERSAFE CLUTCH HUB.....	31
E.01.01.A0001_03 - POWERSAFE CLUTCH HUB.....	33
F01_1_132354 - ENGINE FLANGES.....	35
F.01.01.A0001_02 - ENGINE FLANGES.....	37
G.01.01.A0003_01 - GEARBOX.....	39
G.01.01.A0003_02 - GEARBOX.....	41
H.04.01.A0003_00 - GEARS (328_338).....	43
H.04.01.A0003_01 - GEARS (328_338).....	46
H.04.01.A0003_02 - GEARS (328_338).....	49
I02_1_67059 - WHEELS AXLE.....	52
J02_0_67169 - STEERING COLUMN.....	54
J.02.01.A0003_01 - STEERING COLUMN.....	56
K.02.01.A0003_01 - HANDLEBAR.....	58
L.03.01.A0003_02 - HANDLEBAR CONTROLS.....	60
M.04.01.A0003_00 - CONTROLS.....	63
M.04.01.A0003_01 - CONTROLS.....	66



N.02.01.A0003_02 - BRAKES.....69
P01_1_81340 - WHEELS.....71
Q01_1_81859 - ELECTRIC STARTER.....73
R01_0_67594 - STICKERS.....75
R.02.01.A0003_02 - STICKERS.....77
S.01.01.A0027_00 - ENGINE COVER KIT.....79





Id	Description
A.01.01.A0003_01	ENGINE PROTECTIONES
A.01.01.A0003_02	ENGINE PROTECTIONES
A.01.01.A0003_03	ENGINE PROTECTIONES
B.01.01.A0001_03	POWERSAFE CLUCH CONTROL
B.01.01.A0001_04	POWERSAFE CLUCH CONTROL
B.01.01.A0001_05	POWERSAFE CLUCH CONTROL
B.01.01.A0001_06	POWERSAFE CLUCH CONTROL
C01_1_72820	CYLINDER AND POWERSAFE CLUTCH
C.01.01.A0001_02	CYLINDER AND POWERSAFE CLUTCH
D.01.01.A0001_02	POWERSAFE FILTER AND UNIT
D.01.01.A0001_03	POWERSAFE FILTER AND UNIT
E01_1_132337	POWERSAFE CLUTCH HUB
E.01.01.A0001_02	POWERSAFE CLUTCH HUB
E.01.01.A0001_03	POWERSAFE CLUTCH HUB
F01_1_132354	ENGINE FLANGES
F.01.01.A0001_02	ENGINE FLANGES
G.01.01.A0003_01	GEARBOX
G.01.01.A0003_02	GEARBOX
H.04.01.A0003_00	GEARS (328_338)
H.04.01.A0003_01	GEARS (328_338)
H.04.01.A0003_02	GEARS (328_338)
I02_1_67059	WHEELS AXLE
J02_0_67169	STEERING COLUMN
J.02.01.A0003_01	STEERING COLUMN
K.02.01.A0003_01	HANDLEBAR
L.03.01.A0003_02	HANDLEBAR CONTROLS
M.04.01.A0003_00	CONTROLS
M.04.01.A0003_01	CONTROLS
N.02.01.A0003_02	BRAKES



Id	Description
P01_1_81340	WHEELS
Q01_1_81859	ELECTRIC STARTER
R01_0_67594	STICKERS
R.02.01.A0003_02	STICKERS
S.01.01.A0027_00	ENGINE COVER KIT



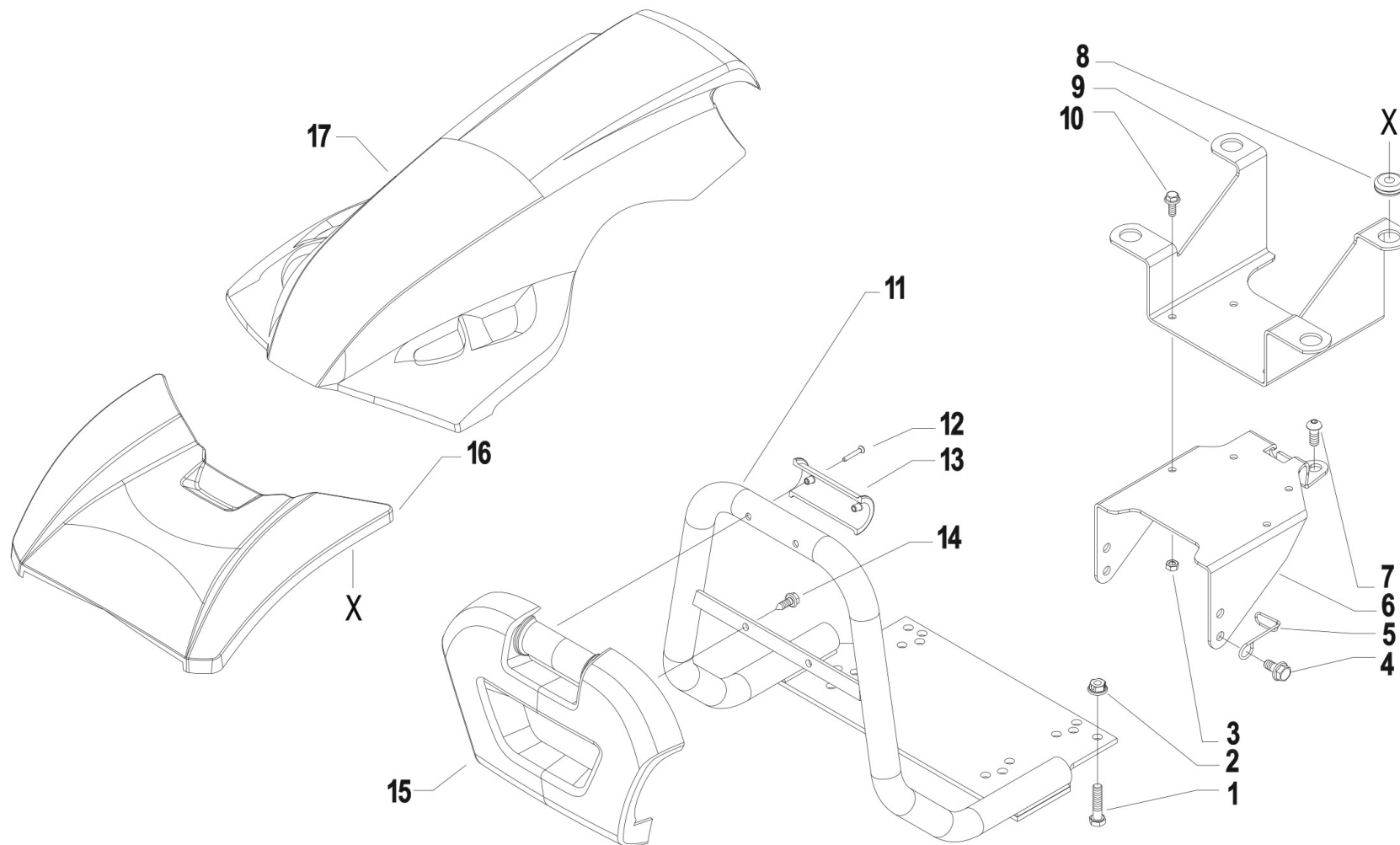

Pos.	Id	Q.ty	Description	Note
1	31112154	1	SCREW TE M8X40 UNI 5739 8G	
2	31241084	1	SELFLOCK NUT M8 6S	
3	31241060	1	HEXAGON SELFLOCK NUT M6	
4	31112171	1	SCREW TE C/F M8X16 DIN 6921	
5	58057266	1	HOLDER	
6	56156246N	1	TUNNEL	
7	31121008	1	SCREW TBCEI M10X16 ISO 7380	
8	58056991	1	CABLE GLAND 90/200/30	
9	56157399	1	HOLDER	
10	31112085	1	SCREW TE M6X16 DIN 6921 8G	
11	59053021H	1	BUMPER C.15LD-ACT-GX ALUM.	For motors GX270/340
11	59053040H	1	ALU COMPLETE BUMPER GX160-200	For motors GX160/200-EX21
11	59056127H	1	BUMPER FOR 740	For engine L70
12	31100451	1	SCREW 3,5X25	Replaces 55252415
13	55257522	1	HALF BEARING	Replaces 55252415
14	31510100	1	RIBBED SCREW 6,3X19 UNI 6950	Replaces 55252415
15	55252503	1	FREGIO ANT.MC 2010 FERRARI	Replaces 55252415
16	55252406	1	GUARD BATTERY BOX	
17	55252405	1	GUARD	



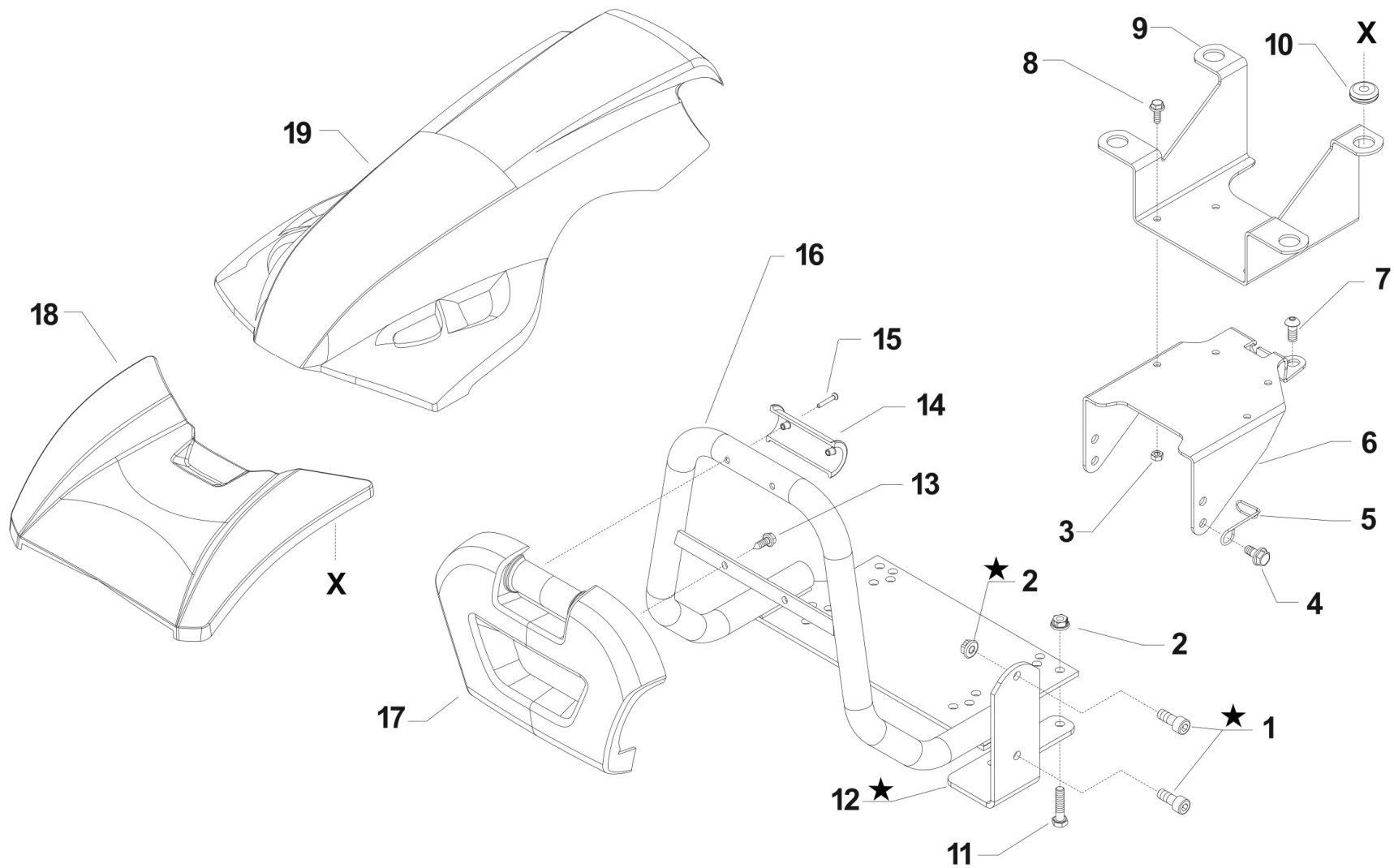

i = info - stop 2 sec. ★ = new part

Pos.	Id	Q.ty	Description	Note
1	31152081		SCREW TCEI M8X20 UNI 5931	KD350
2	31241084		SELFLOCK NUT M8 6S	KD350
3	31241060		HEXAGON SELFLOCK NUT M6	320 - 330
4	31112171		SCREW TE C/F M8X16 DIN 6921	
5	58057266		HOLDER	
6	56156246N		TUNNEL	
7	31121008		SCREW TBCEI M10X16 ISO 7380	
8	31112085		SCREW TE M6X16 DIN 6921 8G	320 - 328 - 330 - 338
9	56157399		HOLDER	320 - 328 - 330 - 338
10	58056991		CABLE GLAND 90/200/30	320 - 328 - 330 - 338
11	31112154		SCREW TE M8X40 UNI 5739 8G	
12	56156136Z		BUMPER FIXING SUPPORT	KD350
13	31510100		RIBBED SCREW 6,3X19 UNI 6950	
14	55252504		HALF BEARING	
15	31100451		SCREW 3,5X25	
16	59053021H		BUMPER C.15LD-ACT-GX ALUM.	GX240 - GX340
16	59053040H		ALU COMPLETE BUMPER GX160-200	GX160 - GX200 - EX21
16	59056127H		BUMPER FOR 740	L70
17	55252503		FREGIO ANT.MC 2010 FERRARI	
18	55252406		GUARD BATTERY BOX	320 - 328 - 330 - 338
19	55252405		GUARD	320 - 328 - 330 - 338



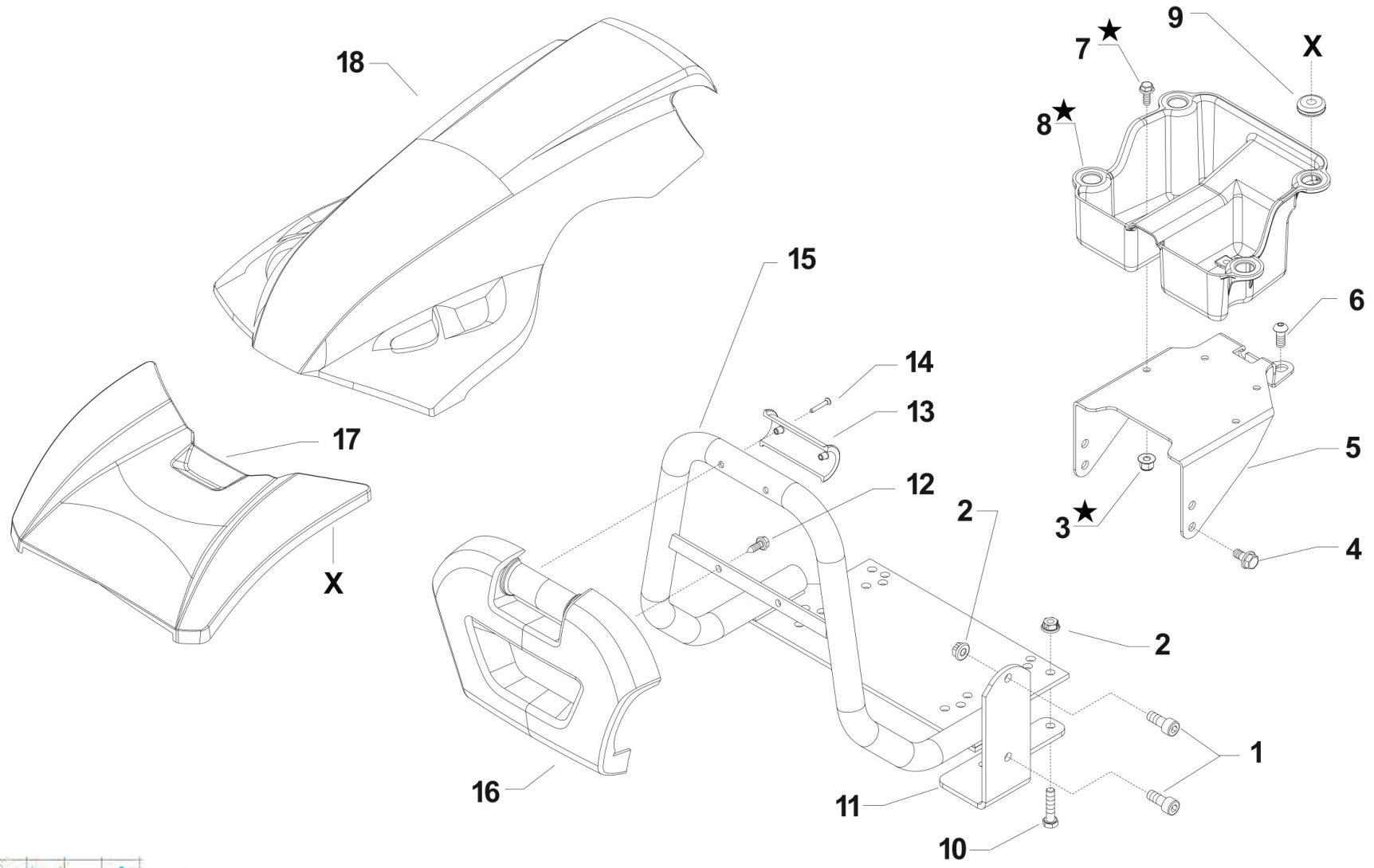

i = info - stop 2 sec. ★ = new part



FERRARI Motor mowers, FERRARI 2-wheel tractors - 338 PS
A.01.01.A0003_03 - ENGINE PROTECTIONS

Pos.	Id	Q.ty	Description	Note
1	31152081		SCREW TCEI M8X20 UNI 5931	KD350
2	31241084		SELFLOCK NUT M8 6S	KD350
3	31241066		SELFLOCK M6 FL NY DIN 6926	320 - 330
4	31112171		SCREW TE C/F M8X16 DIN 6921	
5	56156246N		TUNNEL	
6	31121008		SCREW TBCEI M10X16 ISO 7380	
7	31112081		SCREW TE C/F M6X20 DIN 6921 8G	
8	552C1001		FAIRINGS BOX	
8	58056991		CABLE GLAND 90/200/30	
10	31112154		SCREW TE M8X40 UNI 5739 8G	
11	56156136Z		BUMPER FIXING SUPPORT	KD350
12	31510100		RIBBED SCREW 6,3X19 UNI 6950	
13	55252504		HALF BEARING	
14	31100451		SCREW 3,5X25	
15	59053021H		BUMPER C.15LD-ACT-GX ALUM.	GX270 - GX340
15	59053040H		ALU COMPLETE BUMPER GX160-200	GX160 - GX200 - EX21
15	59056127H		BUMPER FOR 740	L70
16	55252503		FREGIO ANT.MC 2010 FERRARI	
17	55252406		GUARD BATTERY BOX	
18	55252405		GUARD	



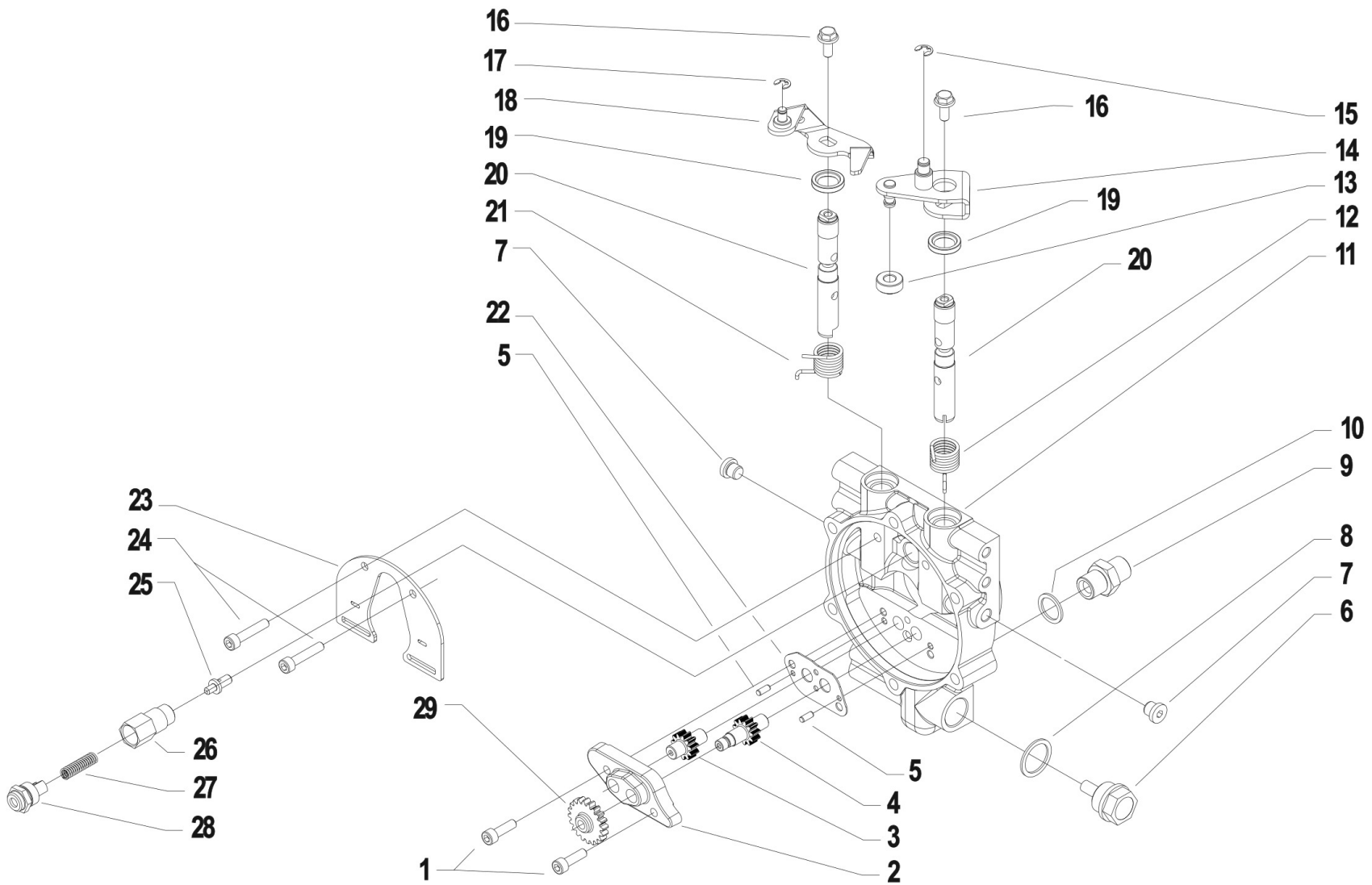

Pos.	Id	Q.ty	Description	Note
1	31152063	1	SCREW TCEI M6X20 UNI 5931	
2	51156214	1	COVER	
3	52456217	1	DRIVEN GEAR	
4	52456223	1	GEAR	
5	34221040	1	CYLINDRICAL PLUG	
6	58170021	1	PLUG	
7	580C0041	1	PLUG	
8	F0844273090	1	GASKET 22X28X1,5 CU 99,5	
9	30000197	1	NIPPLE	
10	31480184	1	COPPER WASHER 16,7x22/1,5	
11	59256200	1	CLUTCH FLANGE	
12	58056222	1	SPRING	
13	55256228	1	ROLLER	
14	59056225Z	1	CLUTCH LEVER	
15	35211060	1	SEEGER RING E 6 UNI 7434	
16	31112084	1	SCREW TE C/F M6X14 DIN 6921 8G	
17	35211050	1	SEEGER RING E 5 UNI 7434	
18	59056298Z	1	LEVER	Replaces 59056230Z from serial 901289
19	38211400	1	OIL SEAL 14X22X4	
20	52456220	1	DISTRIBUTOR	
21	58056221	1	SPRING	
22	56356661	1	COUNTERWEIGHT	
23	56156224	1	SHIELD	
24	31152060	1	SCREW TCEI M6X30 UNI 5931	
25	56456657	1	VALVE	
26	56156658	1	VALVE INSERT/INLET	
27	58056683	1	SPRING	Replaces 58056192 from serial number 883609
28	56356242	1	PLUG	
29	52456235	1	PUMP GEAR	



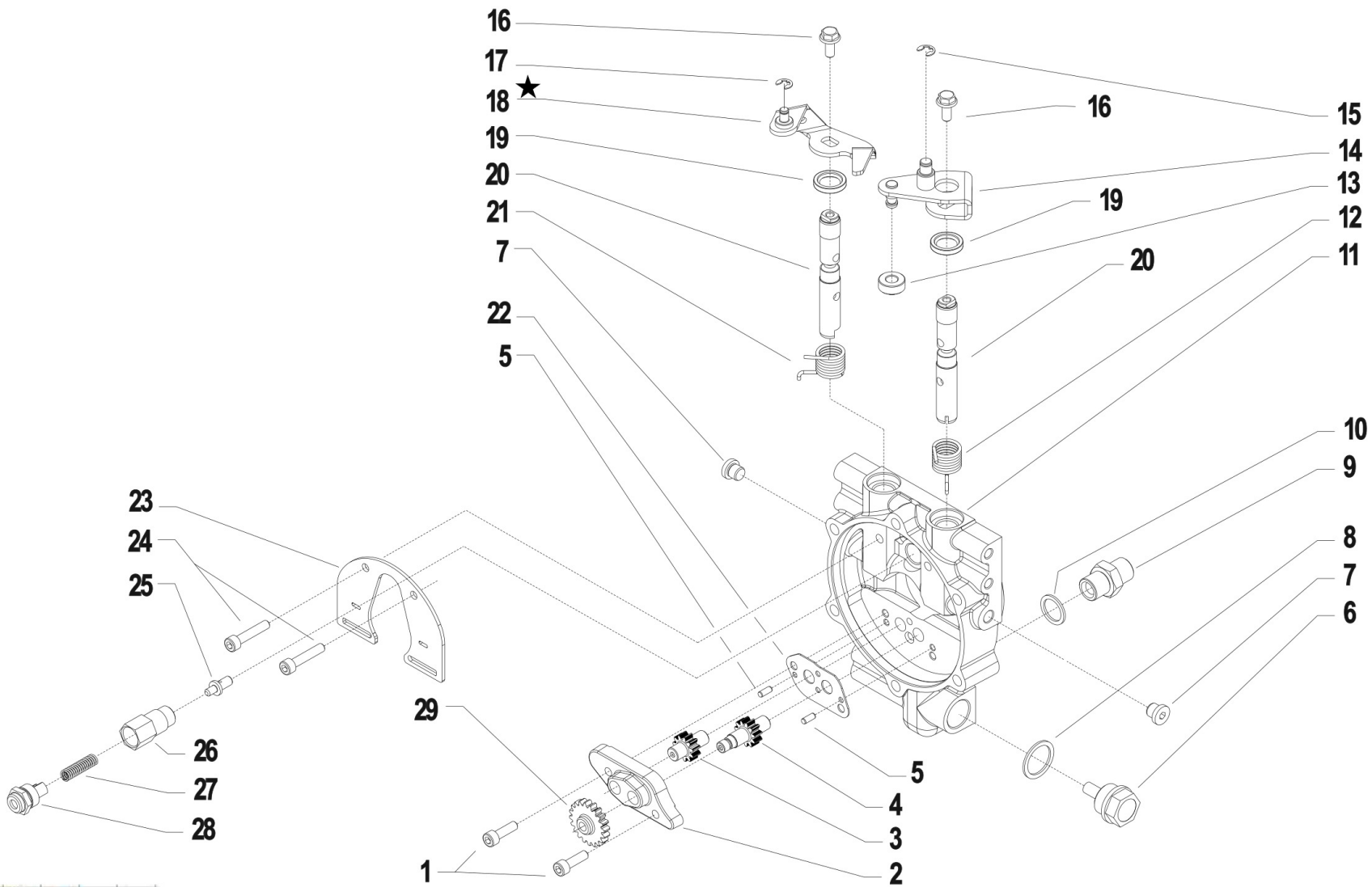

i = info - stop 2 sec. = new part

Pos.	Id	Q.ty	Description	Note
1	31152063		SCREW TCEI M6X20 UNI 5931	
2	51156214		COVER	
3	52456217		DRIVEN GEAR	
4	52456223		GEAR	
5	34221040		CYLINDRICAL PLUG	
6	58170021		PLUG	
7	580C0041		PLUG	
8	F0844273090		GASKET 22X28X1,5 CU 99,5	
9	30000197		NIPPLE	
10	31480184		COPPER WASHER 16,7x22/1,5	
11	59256200		CLUTCH FLANGE	
12	58056222		SPRING	
13	55256228		ROLLER	
14	59056225Z		CLUTCH LEVER	
15	35211060		SEEGER RING E 6 UNI 7434	
16	31112084		SCREW TE C/F M6X14 DIN 6921 8G	
17	35211050		SEEGER RING E 5 UNI 7434	
18	59056748Z		COMPLETE STOP LEVER PS GALV.	REPLACES 58056298Z
19	38211400		OIL SEAL 14X22X4	
20	52456220		DISTRIBUTOR	
21	58056221		SPRING	
22	56356661		COUNTERWEIGHT	
23	56156224		SHIELD	
24	31152060		SCREW TCEI M6X30 UNI 5931	
25	56456657		VALVE	
26	56156658		VALVE INSERT/INLET	
27	58056683		SPRING	Replaces 58056192 from serial number 883609
28	56356242		PLUG	
29	52456235		PUMP GEAR	



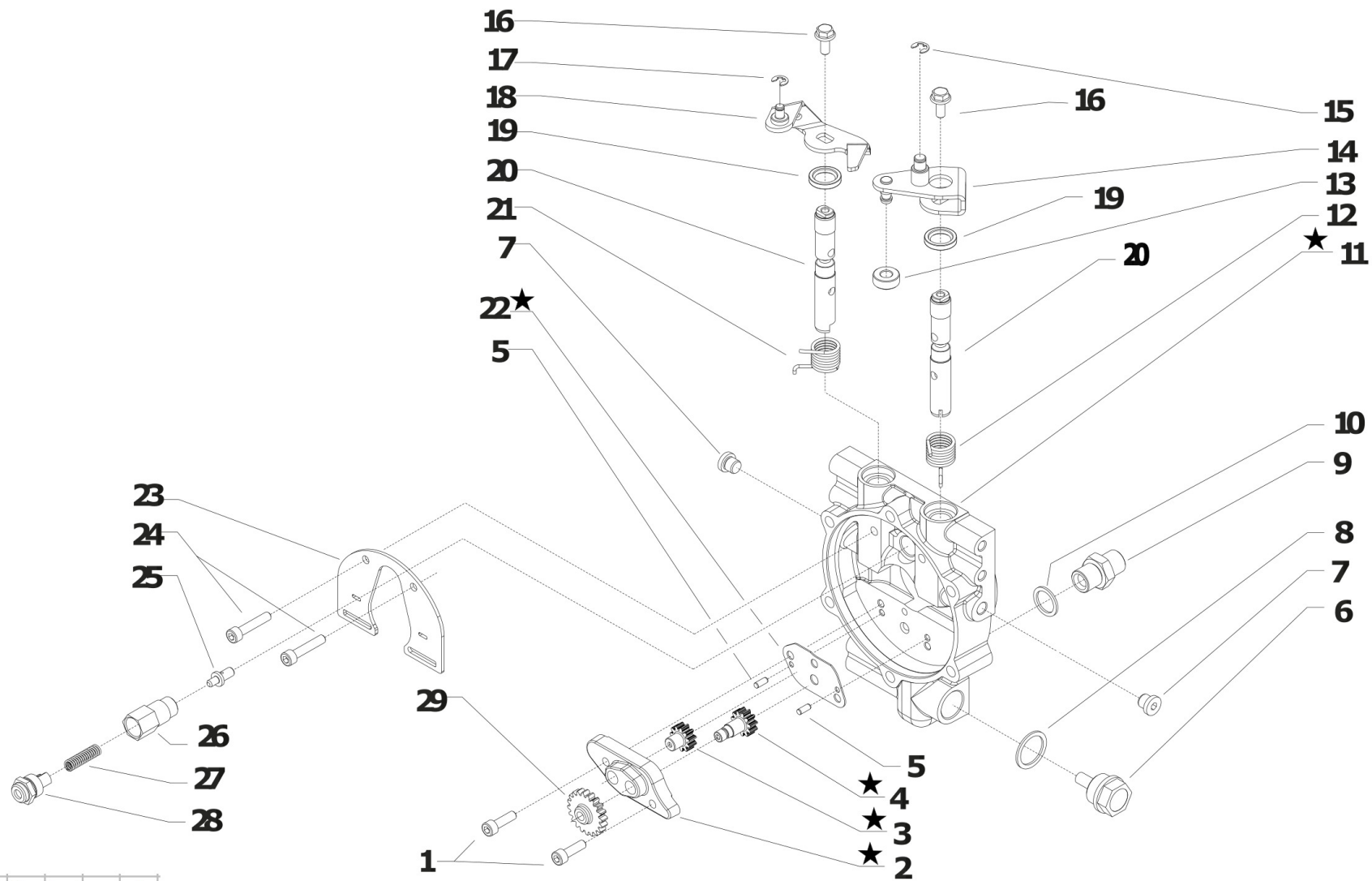

i = info - stop 2 sec. ★ = new part

Pos.	Id	Q.ty	Description	Note
1	31152063		SCREW TCEI M6X20 UNI 5931	
2	56356364		PUMP COVER PS/14	REPLACE 51156214 + 52456217 + 52456223 + 56356661 + 59256200
3	52456371		PUMP GEAR PS/14	REPLACE 51156214 + 52456217 + 52456223 + 56356661 + 59256200
4	52456372		PUMP GEAR	REPLACE 51156214 + 52456217 + 52456223 + 56356661 + 59256200
5	34221040		CYLINDRICAL PLUG	
6	58170021		PLUG	
7	580C0041		PLUG	
8	F0844273090		GASKET 22X28X1,5 CU 99,5	
9	30000197		NIPPLE	
10	31480184		COPPER WASHER 16,7x22/1,5	
11	59256745		POWERSAFE CLUTCH FLANGE	REPLACE 51156214 + 52456217 + 52456223 + 56356661 + 59256200
12	58056222		SPRING	
13	55256228		ROLLER	
14	59056225Z		CLUTCH LEVER	
15	35211060		SEEGER RING E 6 UNI 7434	
16	31112084		SCREW TE C/F M6X14 DIN 6921 8G	
17	35211050		SEEGER RING E 5 UNI 7434	
18	59056748Z		COMPLETE STOP LEVER PS GALV.	
19	38211400		OIL SEAL 14X22X4	
20	52456220		DISTRIBUTOR	
21	58056221		SPRING	
22	56356747		PUMP RECEPTOR PS/14	REPLACE 51156214 + 52456217 + 52456223 + 56356661 + 59256200
23	56156224		SHIELD	
24	31152060		SCREW TCEI M6X30 UNI 5931	
25	56456657		VALVE	
26	56156658		VALVE INSERT/INLET	
27	58056683		SPRING	Replaces 58056192 from serial number 883609
28	56356242		PLUG	
29	52456235		PUMP GEAR	



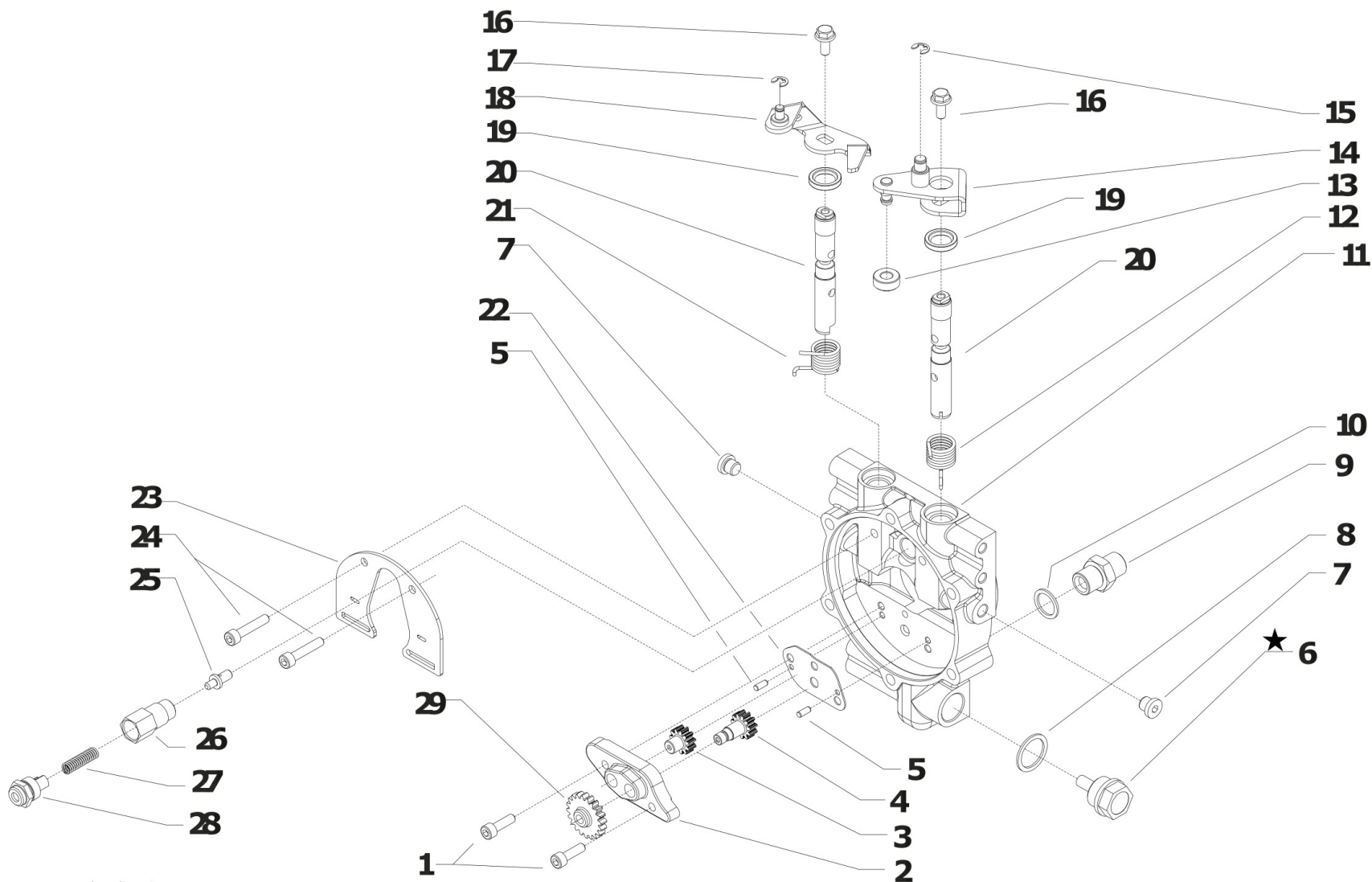

  [Click for info](#)

★ = new part



Pos.	Id	Q.ty	Description	Note
1	31152063		SCREW TCEI M6X20 UNI 5931	
2	56356364		PUMP COVER PS/14	REPLACE 51156214 + 52456217 + 52456223 + 56356661 + 59256200
3	52456371		PUMP GEAR PS/14	REPLACE 51156214 + 52456217 + 52456223 + 56356661 + 59256200
4	52456372		PUMP GEAR	REPLACE 51156214 + 52456217 + 52456223 + 56356661 + 59256200
5	34221040		CYLINDRICAL PLUG	
6	581C2554		TAPPO MAGNETICO M22X1,5	REPLACES 58170021
7	580C0041		PLUG	
8	F0844273090		GASKET 22X28X1,5 CU 99,5	
9	30000197		NIPPLE	
10	31480184		COPPER WASHER 16,7x22/1,5	
11	59256745		POWERSAFE CLUTCH FLANGE	REPLACE 51156214 + 52456217 + 52456223 + 56356661 + 59256200
12	58056222		SPRING	
13	55256228		ROLLER	
14	59056225Z		CLUTCH LEVER	
15	35211060		SEEGER RING E 6 UNI 7434	
16	31112084		SCREW TE C/F M6X14 DIN 6921 8G	
17	35211050		SEEGER RING E 5 UNI 7434	
18	59056748Z		COMPLETE STOP LEVER PS GALV.	
19	38211400		OIL SEAL 14X22X4	
20	52456220		DISTRIBUTOR	
21	58056221		SPRING	
22	56356747		PUMP RECEPTOR PS/14	REPLACE 51156214 + 52456217 + 52456223 + 56356661 + 59256200
23	56156224		SHIELD	
24	31152060		SCREW TCEI M6X30 UNI 5931	
25	56456657		VALVE	
26	56156658		VALVE INSERT/INLET	
27	58056683		SPRING	Replaces 58056192 from serial number 883609
28	56356242		PLUG	
29	52456235		PUMP GEAR	



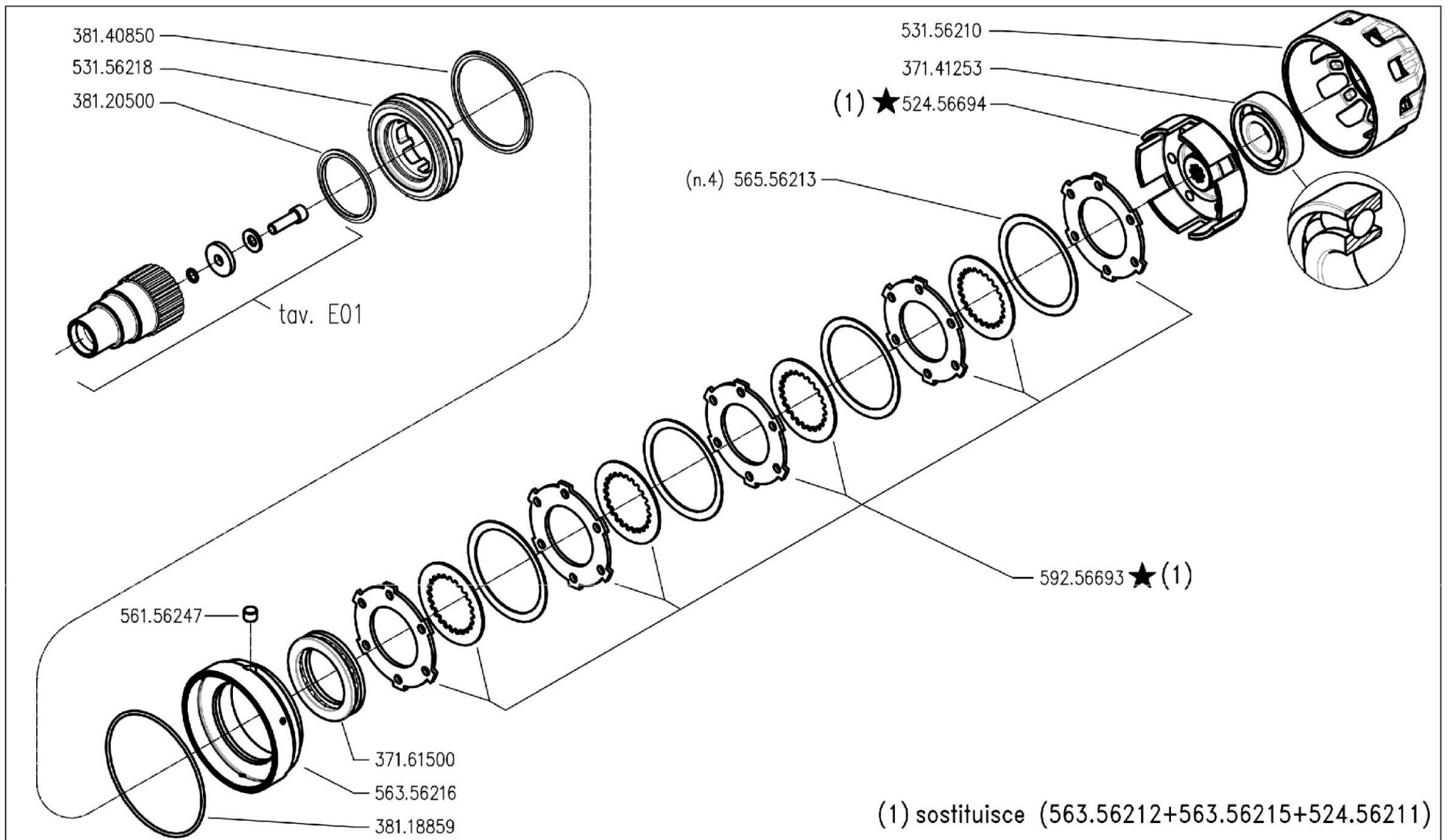

	300 serie PS PowerSafe®	CILINDRO E FRIZIONE POWERSAFE CYLINDER AND POWERSAFE CLUTCH CILINDRO Y EMBRAGUE POWERSAFE	DALLA MACCHINA DE LA MAQUINA DE LA MACHINA FROM THE MACHINE AB DER MASCHINE	Rev. C01 1	DATE: BCS - Scala 1:6
		CYLINDER ET EMBRAYAGE POWERSAFE ZILINDER UND POWERSAFE KUPPLUNG	★ N. 852604	04/2010	

Pos.	Id	Q.ty	Description	Note
37141253	37141253	1	BEARING 7305-BJP OBL 25x62x17	
37161500	37161500	1	BEARING 51110 (50X70X14)	
38118859	38118859	1	O-RING OR 3375 (94,92X2,62)	
38120500	38120500	1	RING I/GR-L 0500-A POLYPAC	
38140850	38140850	1	RING E/GR-L 0850-A POLYPAC	
52456694	52456694	1	CLUTCH HOUSING	
53156210	53156210	1	SUMP	
53156218	53156218	1	PISTON	
56156247	56156247	1	PIN	
56356216	56356216	1	RING	
56556213	56556213	1	SPRING	
59256693	59256693	1	9 DISC CLUTCH	



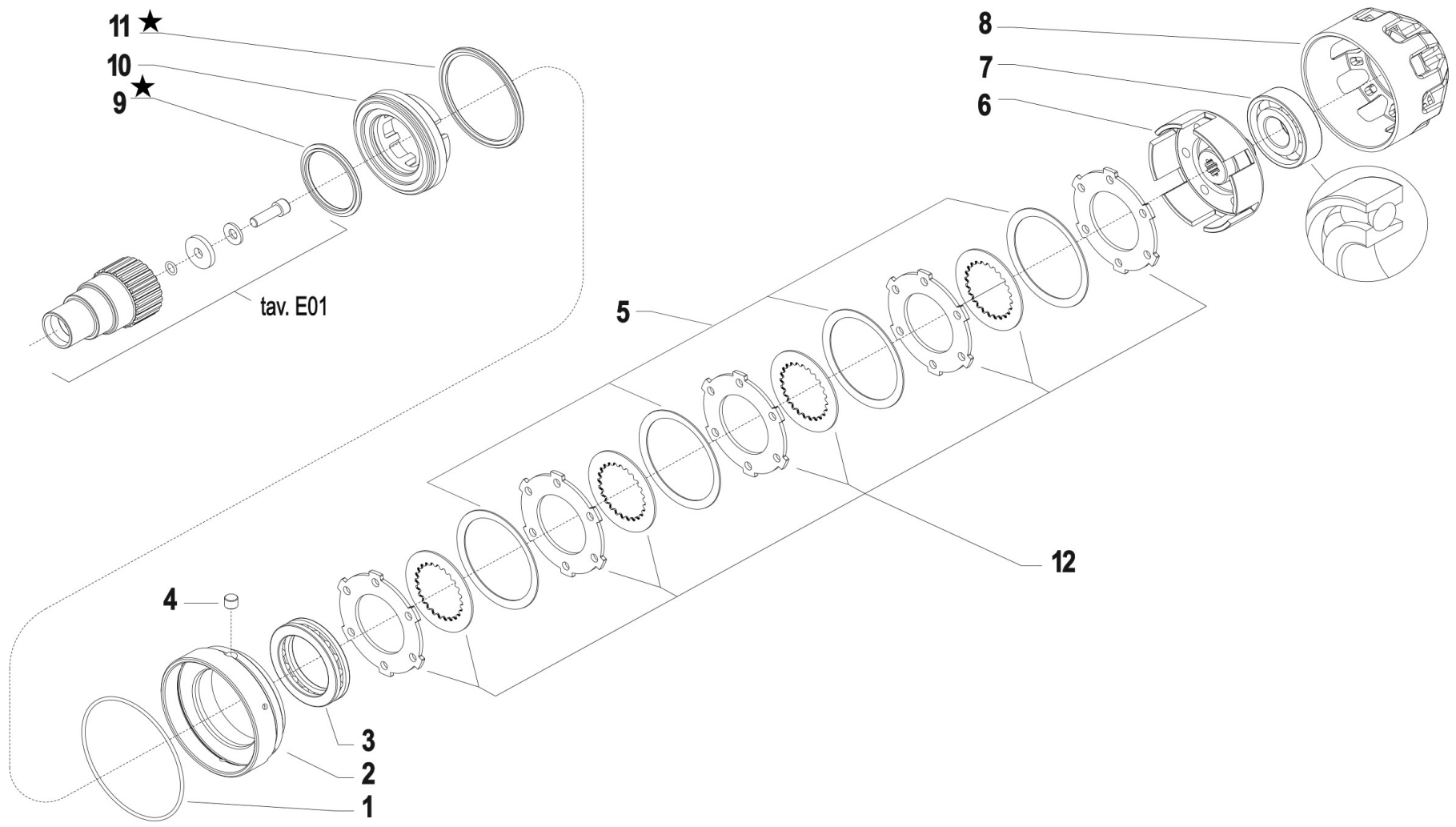



i = info - stop 2 sec. ★ = new part



Pos.	Id	Q.ty	Description	Note
1	38118859		O-RING OR 3375 (94,92X2,62)	
2	56356216		RING	
3	37161500		BEARING 51110 (50X70X14)	
4	56156247		PIN	
5	56556213		SPRING	n. 4
6	52456694		CLUTCH HOUSING	Replaces 56356212 + 56356215 + 52456211
7	37141253		BEARING 7305-BJP OBL 25x62x17	
8	53156210		SUMP	
9	38120501		RING PTFE PRP 01A02-0500-A-32	REPLACE 38120500 + 38140850
10	53156218		PISTON	
11	38140851		RING PTFE PRP02A02-0850-A-32-N	REPLACE 38120500 + 38140850
12	59256693		9 DISC CLUTCH	Replaces 56356212 + 56356215 + 52456211

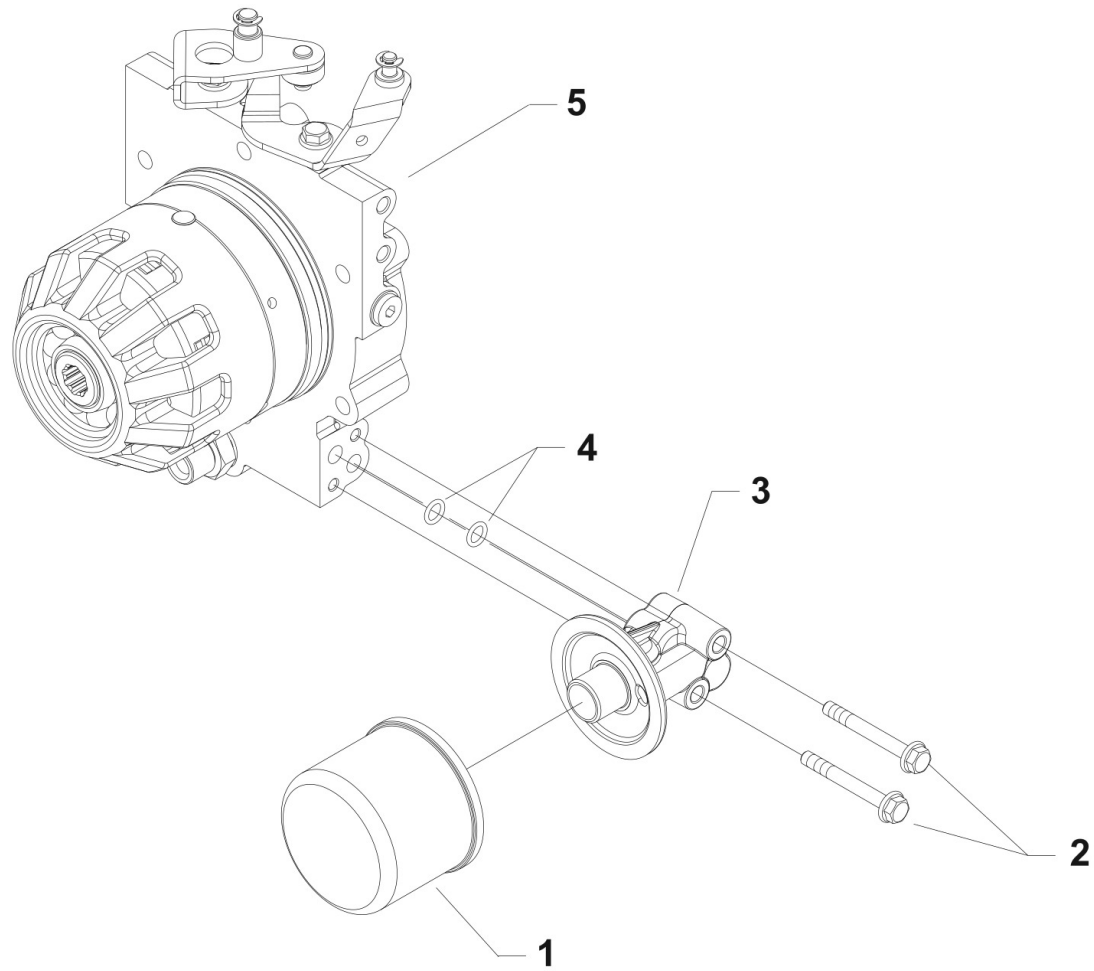



Pos.	Id	Q.ty	Description	Note
1	58056208	1	HYDRAULIC OIL FILTER	
2	31112099	1	SCREW TE C/F M6X50 DIN 6921 8G	
3	53156209	1	CONNECTION	
3	53156659	1	CONNECTION	Powersafe EasyDrive
4	38110873	1	O-RING 108 (8,73X1,78)	
5	59256035	1	POWERSAFE CLUTCH ASSY Q19	For motors GX160/200
5	59256036	1	POWERSAFE CLUTCH	For motors GX240/270-EX21
5	59256037	1	CLUTCH FOR POWERSAFE Q25.4 (3/8)	For motors GX340/390
5	59256038	1	POWERSAFE CLUTCH	For motors 15LD350/440-L70/100
5	59256039	1	POWERSAFE CLUTCH ASSY	For motors 15LD500/3LD510



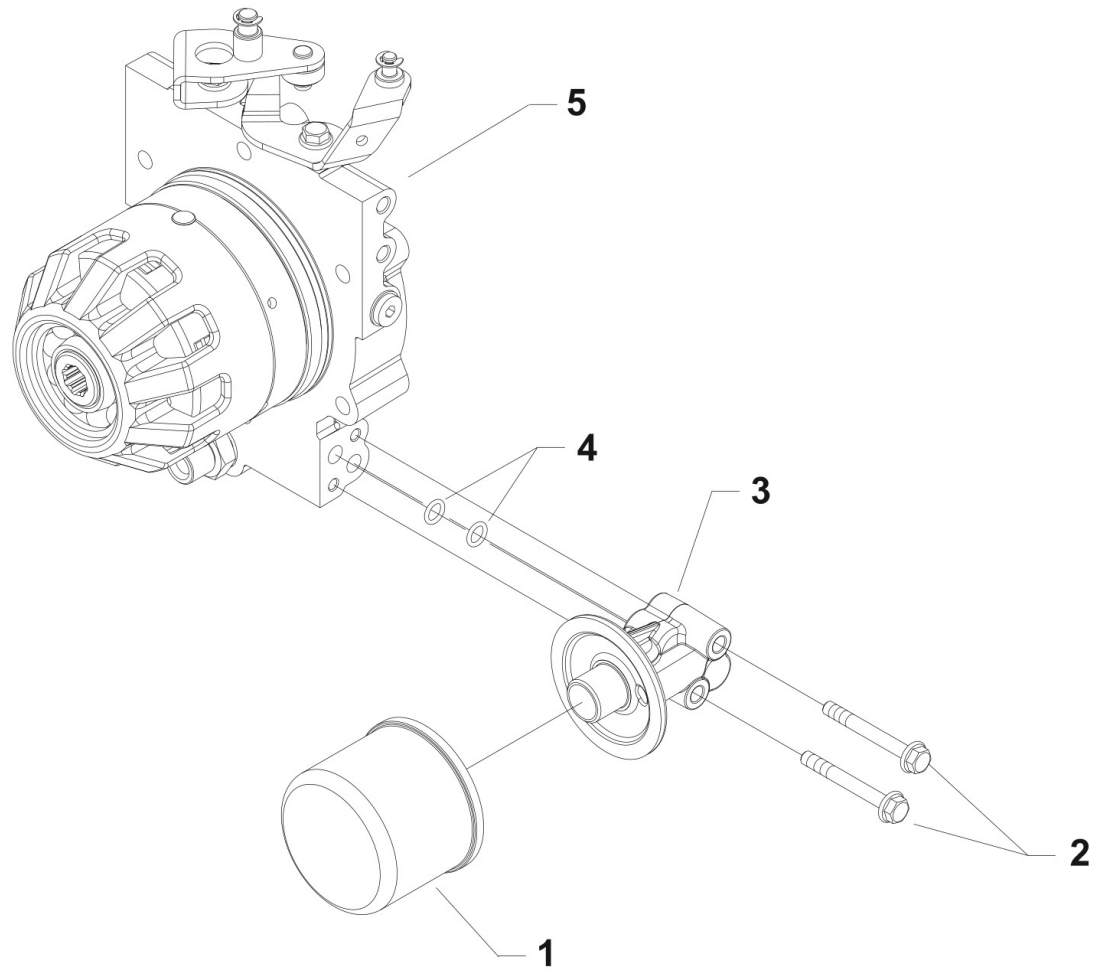

Pos.	Id	Q.ty	Description	Note
1	58056208		HYDRAULIC OIL FILTER	
2	31112099		SCREW TE C/F M6X50 DIN 6921 8G	
3	53156209		CONNECTION	
3	53156659		CONNECTION	730 ED
4	38110873		O-RING 108 (8,73X1,78)	
5	59256035		POWERSAFE CLUTCH ASSY Q19	GX 160/GX200 - EX21 - GP160
5	59256036		POWERSAFE CLUTCH	GX 240/GX 270 - B&S 1450/B&S 2100
5	59256037		CLUTCH FOR POWERSAFE Q25.4 (3/8)	GX 340/GX390 - EX35
5	59256038		POWERSAFE CLUTCH	15LD350/440 - L70 / L100 - KD350 / KD440
5	59256039		POWERSAFE CLUTCH ASSY	15LD500/3LD510



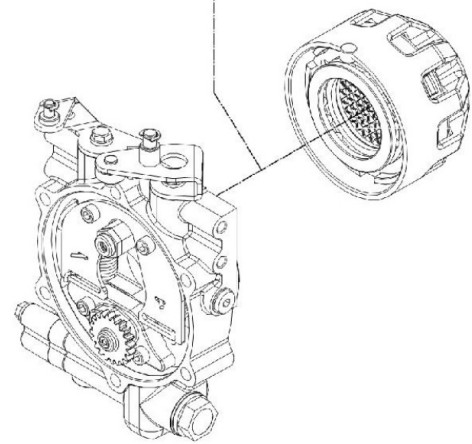
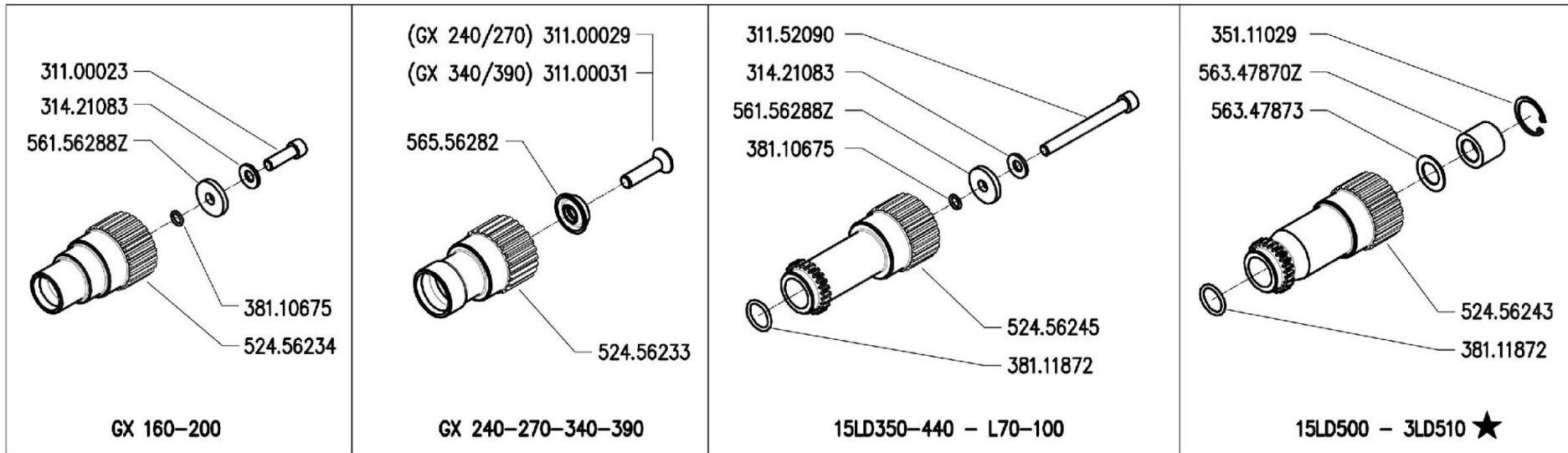

700 serie PS
PowerSafe®

MOZZI FRIZIONE POWERSAFE

POWERSAFE CLUTCH HUBS
CUBOS EMBRAGUE POWERSAFE

MOYEURS EMBRAYAGE POWERSAFE
NABEN POWERSAFE KUPPLUNG

DALLA MACCHINA
DE LA MAQUINA
DE LA MACHINA
FROM THE MACHINE
AB DER MASCHINE

★ N.

AGGIORNAMENTO
APLAZAMIENTO
MISE A JOUR
REVISION
ANPASSUNG

E01

Rev.
1

11/2010

DITE BCS - Scala 1:6



Pos.	Id	Q.ty	Description	Note
31100023	31100023	1	SCREW 5/16-24 X 1 UNF 8G	
31100029	31100029	1	SCREW TSVEI 7/16-20X1 1/2 UNF8G	
31100031	31100031	1	SCREW TSVEI 3/8-24X1 1/2 UNF 8G	
31152090	31152090	1	SCREW TCEI M8x80 UNI5931	
31421083	31421083	1	WASHER	
35111029	35111029	1	SEEGER RING I 28 UNI 7437	
38110675	38110675	1	O-RING 106 (6,75X1,78)	
38111872	38111872	1	O-RING 3075 (18,72x2,62)	
52456233	52456233	1	HUB Q25	
52456234	52456234	1	HUB Q19	
52456243	52456243	1	HUB	
52456245	52456245	1	HUB	
56347873	56347873	1	WASHER	
56556282	56556282	1	WASHER D.25,4	
56156288Z	56156288Z	1	SPECIAL WASHER SP.4	
56347870Z	56347870Z	1	SPECIAL NUT	



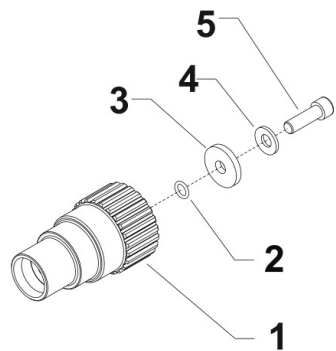

Gx160 - 200
Ex21★-Gp160★

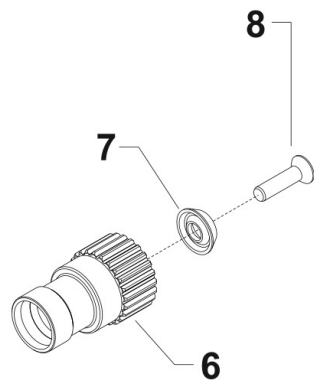

Gx240 - 270 - 340 - 390
B&S 1450 - B&S 2100★

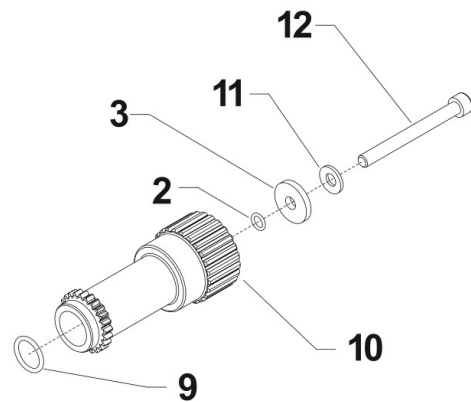

15LD350 - 440 - L70 - L100
Kd350★-Kd440★

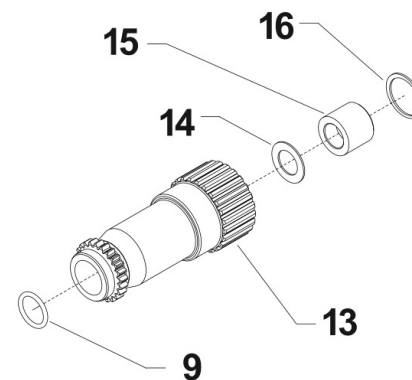

15LD500 - 3LD510

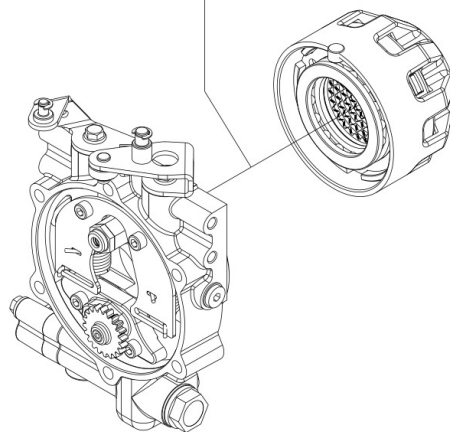

i = info - stop 2 sec. ★ = new part

Pos.	Id	Q.ty	Description	Note
1	52456234		HUB Q19	
2	38110675		O-RING 106 (6,75X1,78)	
3	56156288Z		SPECIAL WASHER SP.4	
4	31421083		WASHER	
5	31100023		SCREW 5/16-24 X 1 UNF 8G	
6	52456233		HUB Q25	
7	56556282		WASHER D.25,4	
8	31100029		SCREW TSVEI 7/16-20X1 1/2 UNF8G	GX 240 /270
8	31100031		SCREW TSVEI 3/8-24X1 1/2 UNF 8G	GX 340 /390
9	38111872		O-RING 3075 (18,72x2,62)	
10	52456245		HUB	
11	31421083		WASHER	
12	31152090		SCREW TCEI M8x80 UNI5931	
13	52456243		HUB	
14	56347873		WASHER	
15	56347870Z		SPECIAL NUT	
16	35111029		SEEGER RING I 28 UNI 7437	



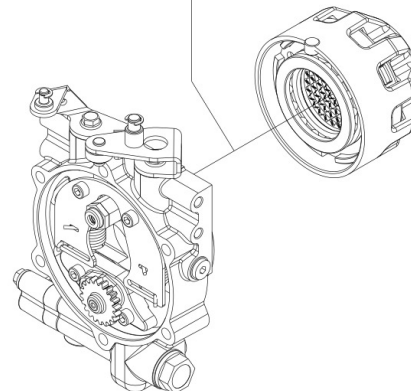
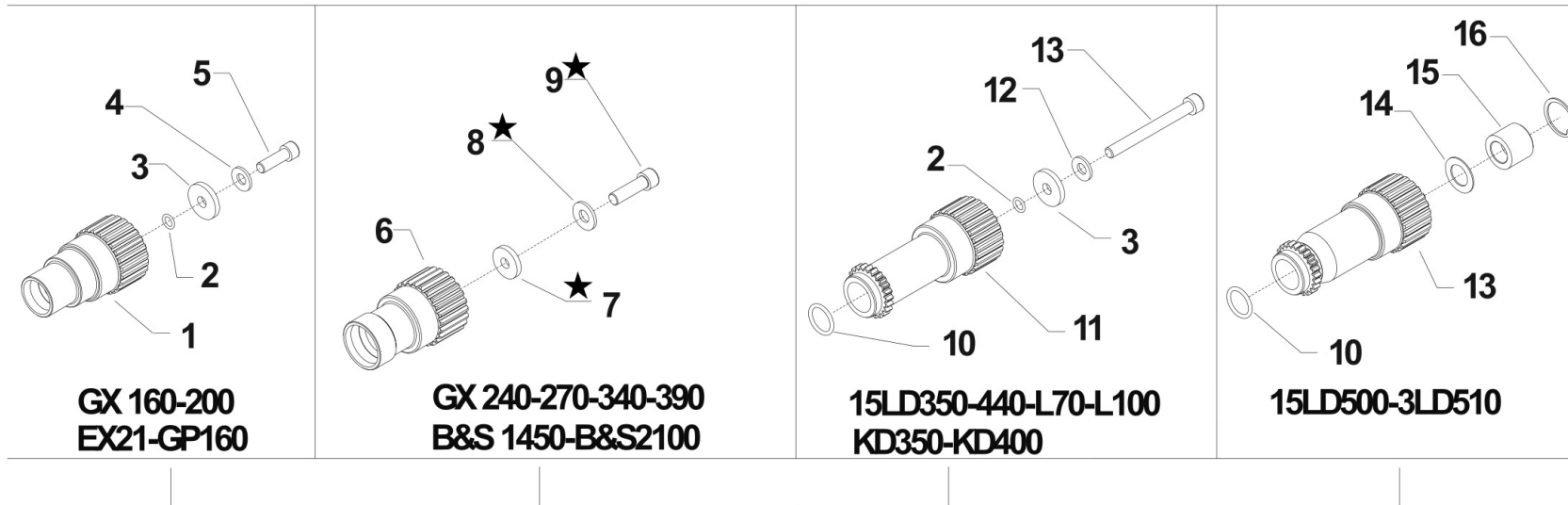

i = info - stop 2 sec. ★ = new part

Pos.	Id	Q.ty	Description	Note
1	52456234		HUB Q19	
2	38110675		O-RING 106 (6,75X1,78)	
3	56156288Z		SPECIAL WASHER SP.4	
4	31421083		WASHER	
5	31100023		SCREW 5/16-24 X 1 UNF 8G	
6	52456233		HUB Q25	
7	56156743		WASHER 30X11.5X3	GX240-270/REPLACE 31100029+31100031+56556282
7	561C0421		WASHER	GX340-390/REPLACE 31100029+31100031+56556282
8	31421101		WASHER 10 DIN 679	REPLACE 31100029+31100031+56556282/GX340-390
8	31421130		WASHER	
9	31100032		SCREW TCCEI 7/16-20 X 1-1/2	GX240-270/REPLACE 31100029+31100031+56556282
9	31100033		SCREW TCCEI 3/8-24 X 1-1/2	GX340-390/REPLACE 31100029+31100031+56556282
10	38111872		O-RING 3075 (18,72x2,62)	
11	52456245		HUB	
12	31421083		WASHER	
13	31152090		SCREW TCEI M8x80 UNI5931	
14	56347873		WASHER	
15	56347870Z		SPECIAL NUT	
16	35111029		SEEGER RING 1 28 UNI 7437	



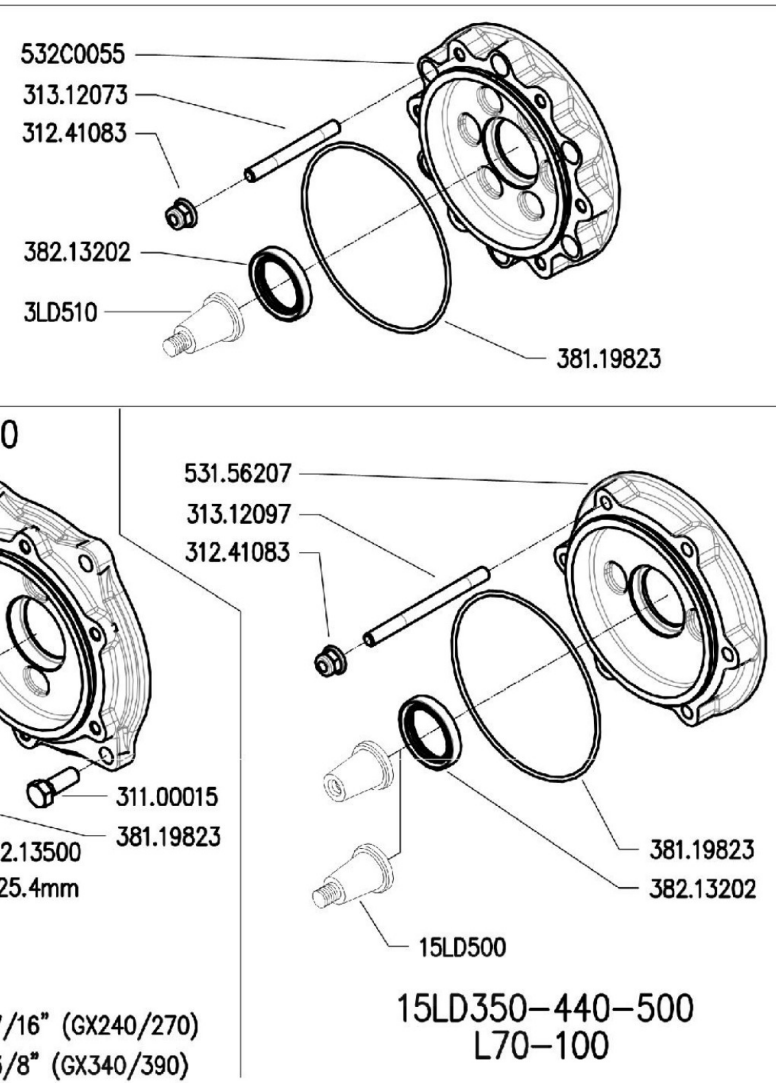
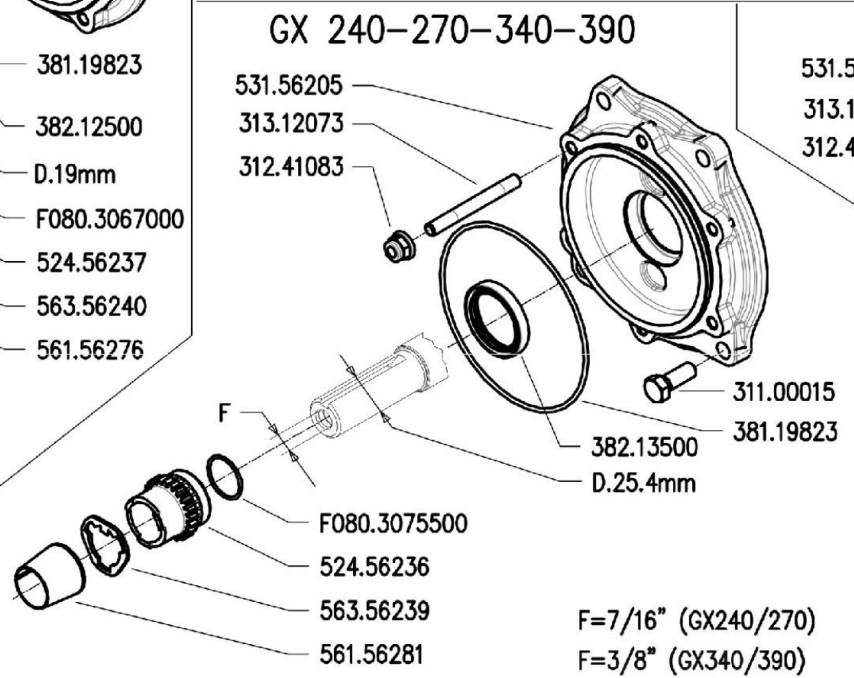
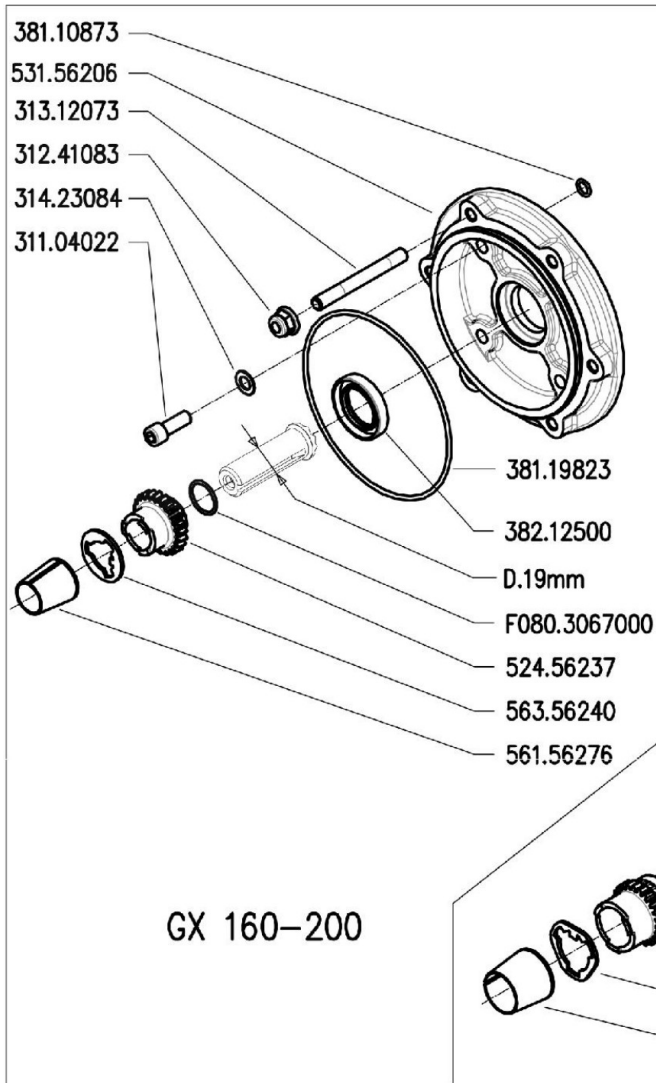

	700 serie PS PowerSafe®	ENGINE FLANGES	FLANGIE MOTORE	DALLA MACCHINA DE LA MAQUINA DE LA MACHINE AB DER MASCHINE	AGGIORNAMENTO	F01	Rev.
		BRIDAS MOTOR	BRIDES MOTEUR		MOTOR FLANSCH		★ N.
					ANPASSUNG	11/2010	



DITE BCS - Scala 1:5

Pos.	Id	Q.ty	Description	Note
31100015	31100015	1	SCREW TE 3/8X1	
31104022	31104022	1	SCREW TCEI 5/16X7/8 UNF 12K	
31241083	31241083	1	SELFLOCK NUT M8	
31312073	31312073	1	STUD BOLT M8X73X14X20 8G	
31312097	31312097	1	STUD BOLT M8X98X16X28 8G	
31423084	31423084	1	SPRING WASHER 8,4	
38110873	38110873	1	O-RING 108 (8,73X1,78)	
38119823	38119823	1	O-RING 3450 (113,97x2,62)	
38212500	38212500	1	OIL SEAL 25X40X7	
38213202	38213202	1	OIL SEAL 32X45X7	
38213500	38213500	1	OIL SEAL 35X47X7	
52456236	52456236	1	PUMP GEAR	
52456237	52456237	1	PUMP GEAR	
53156205	53156205	1	ENGINE FLANGE Q25	
53156206	53156206	1	ENGINE FLANGE Q19	
53156207	53156207	1	ENGINE FLANGE	
532C0055	532C0055	1	ACT ENGINE FLANGE	
56156276	56156276	1	SLEEVE D.19	
56156281	56156281	1	CENTRING BUSH D.25,4	
56356239	56356239	1	FEEDER Q25	
56356240	56356240	1	TRANSMISSION	
F0803067000	F0803067000	1	O-RING 2075 (18,77X1,78)	
F0803075500	F0803075500	1	O-RING 2100 (25,12X1,78)	



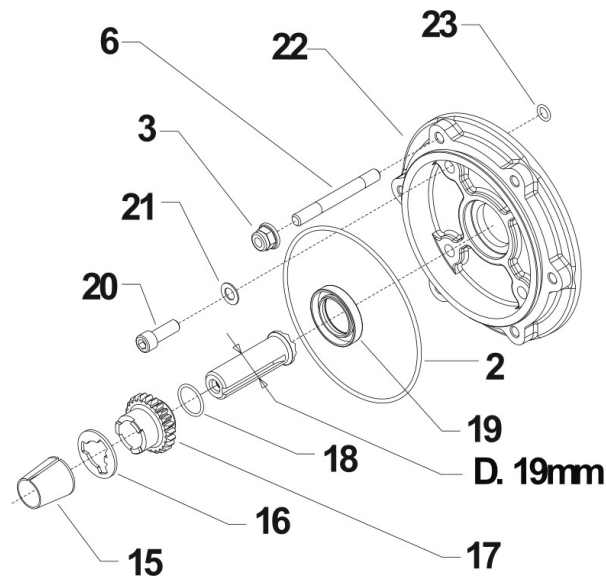

GX 160 - 200
Ex21 - Gp160★

3LD510

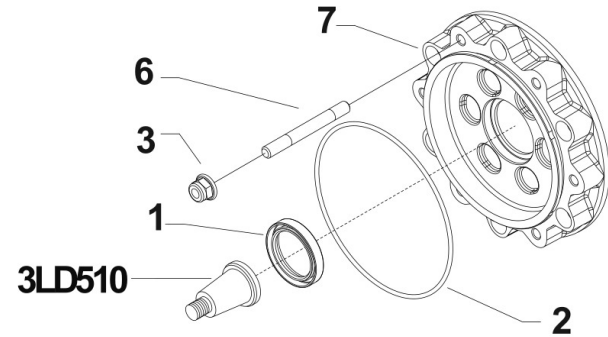

B&S 2100★ B&S 1450★
GX 240 - 270 - 340 - 390

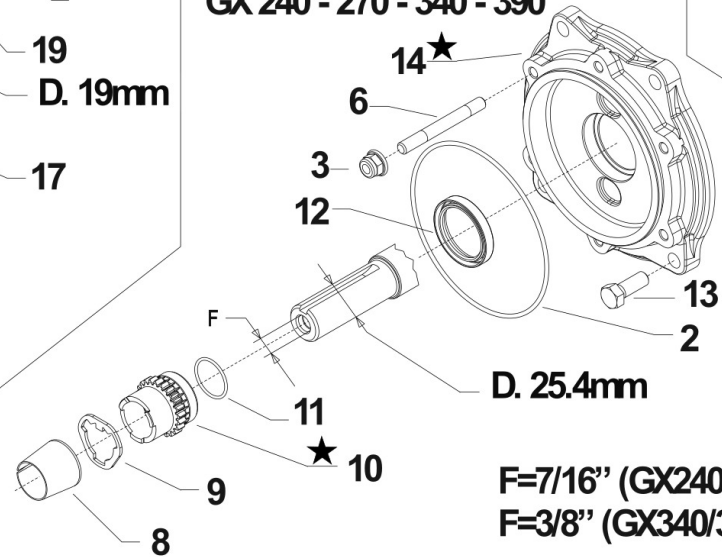

D. 25.4mm

F=7/16" (GX240/270)
F=3/8" (GX340/390)

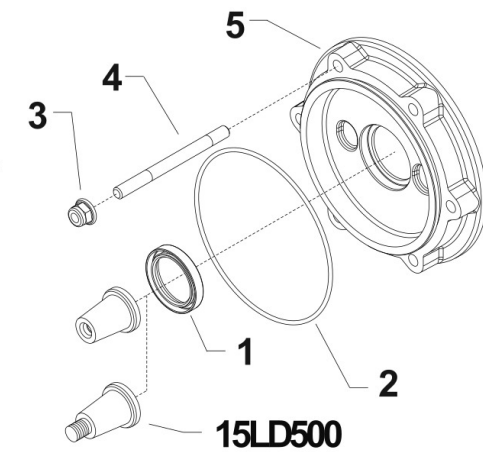

15LD350 - 440 - 500
Kd350★ - Kd440★
L70 - L100



i = info - stop 2 sec. ★ = new part

Pos.	Id	Q.ty	Description	Note
1	38213202		OIL SEAL 32X45X7	
2	38119823		O-RING 3450 (113,97x2,62)	
3	31241083		SELFLOCK NUT M8	
4	31312097		STUD BOLT M8X98X16X28 8G	
5	53156207		ENGINE FLANGE	
6	31312073		STUD BOLT M8X73X14X20 8G	
7	532C0055		ACT ENGINE FLANGE	
8	56156281		CENTRING BUSH D.25,4	
9	56356239		FEEDER Q25	
10	52456236		PUMP GEAR	
10	52456352		PUMP GEAR	EX 35 - B&S 2100
11	F0803075500		O-RING 2100 (25,12X1,78)	
12	38213500		OIL SEAL 35X47X7	
13	31100015		SCREW TE 3/8X1	
14	53156205		ENGINE FLANGE Q25	
14	53256692		ENGINE FLANGE B&S 2100	B&S 2100
15	56156276		SLEEVE D.19	
16	56356240		TRANSMISSION	
17	52456237		PUMP GEAR	
18	F0803067000		O-RING 2075 (18,77X1,78)	
19	38212500		OIL SEAL 25X40X7	
20	31104022		SCREW TCEI 5/16X7/8 UNF 12K	
21	31423084		SPRING WASHER 8,4	
22	53156206		ENGINE FLANGE Q19	
23	38110873		O-RING 108 (8,73X1,78)	



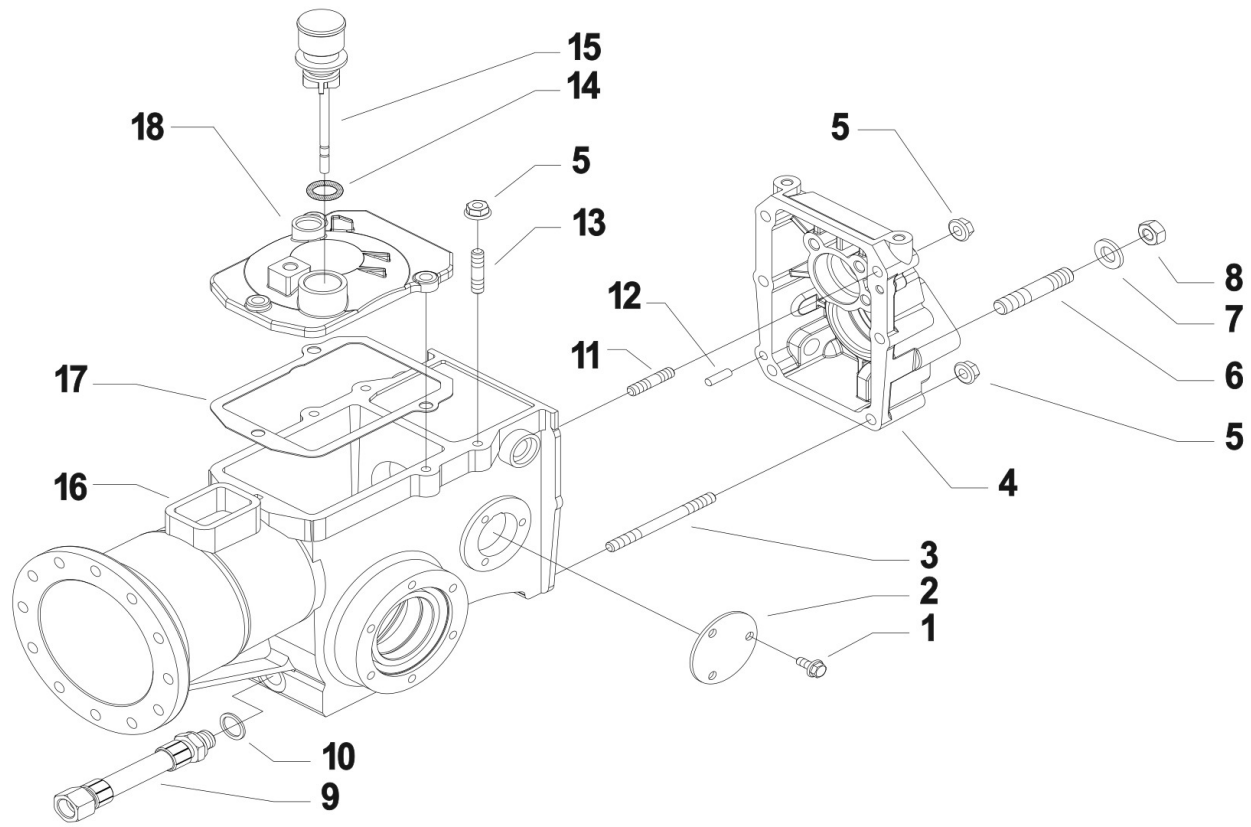

Pos.	Id	Q.ty	Description	Note
1	31112083	1	SCREW M6X12	
2	56147520Z	1	COVER	
3	31312094	1	STUD BOLT M8X68X14X36	
4	53156332V	1	REAR COVER	
5	31241084	1	SELFLOCK NUT M8 6S	
6	31312125	1	STUD BOLT 64XM12X1,25X26XM12X30 8G	
7	31421132	1	WASHER 13X24X2,8	
8	31221121	1	NUT M12X1,25	
9	59056248	1	SUCTION SHORT HOSE	
10	31480184	1	COPPER WASHER 16,7x22/1,5	
11	31312086	1	STUD BOLT M8X56X20X14	
12	58043053	1	CYLINDRICAL PLUG	
13	31312082	1	STUD BOLT M8X38X14X20	
14	55102678	1	RUBBER RING	
15	59056672	1	OIL LEVEL CAP W/SHAFT	
16	53156203V	1	BOX CASING	
17	58043117	1	COVER GASKET	
18	53143128V	1	COVER	Pour les modèles Série 310/320/328 PS
18	53143875V	1	GEARBOX HOUSING COVER	Pour les modèles 330/338 de la série PS



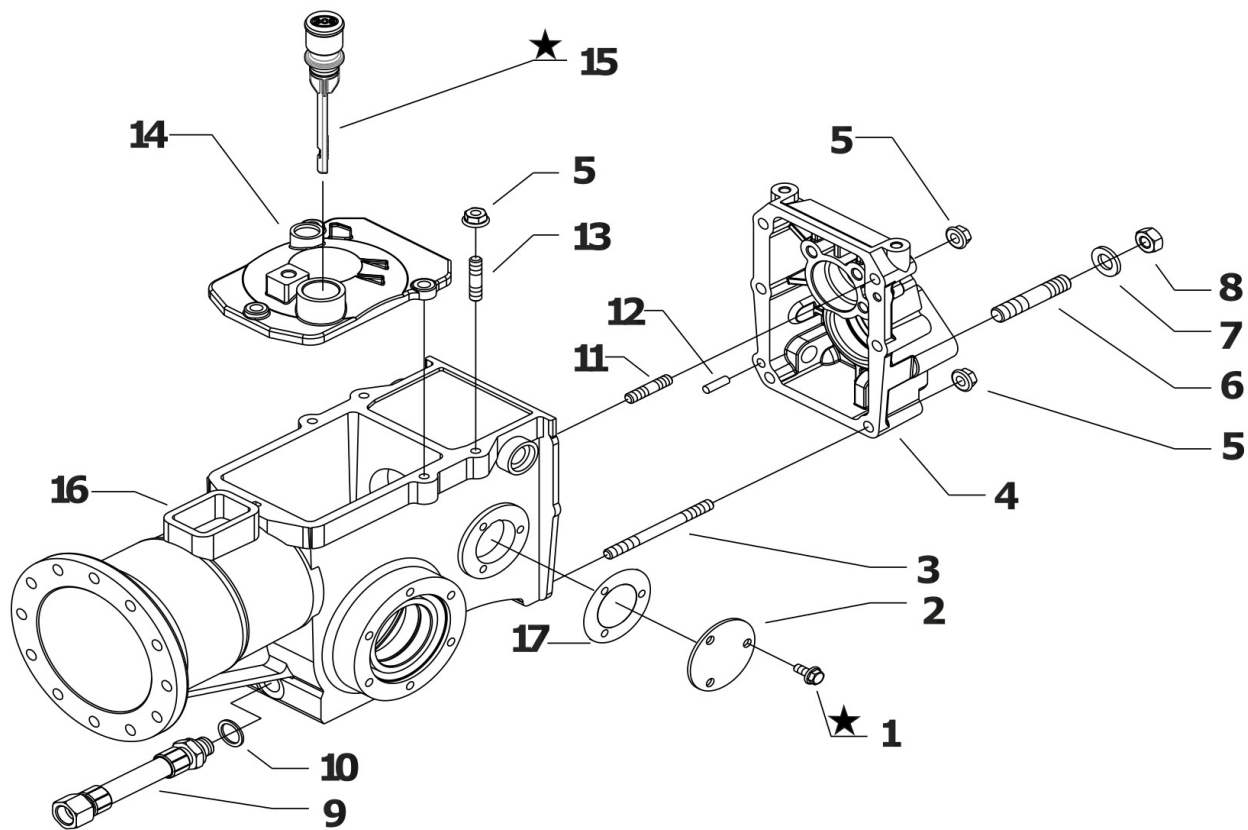

[Click for info](#)

★ = new part

Pos.	Id	Q.ty	Description	Note
1	31112079		VITE TE C/F M6X12 DIN 6921 RVS	REPLACES 31112083
2	56147520Z		COVER	
3	31312094		STUD BOLT M8X68X14X36	
4	53156332N		REAR COVER	
5	31241084		SELFLOCK NUT M8 6S	
6	31312125		STUD BOLT 64XM12X1,25X26XM12X30 8G	
7	31421132		WASHER 13X24X2,8	
8	31221121		NUT M12X1,25	
9	59056248		SUCTION SHORT HOSE	
10	31480184		COPPER WASHER 16,7x22/1,5	
11	31312086		STUD BOLT M8X56X20X14	
12	58043053		CYLINDRICAL PLUG	
13	31312082		STUD BOLT M8X38X14X20	
14	53143128B		COVER	For models 710/720/728 PS Series
14	53143875N		GEARBOX HOUSING COVER	For models 730/738 PS Series
15	59256762		OIL CAP M COMPLETE	REPLACES 59056672
16	53156203N		BOX CASING	



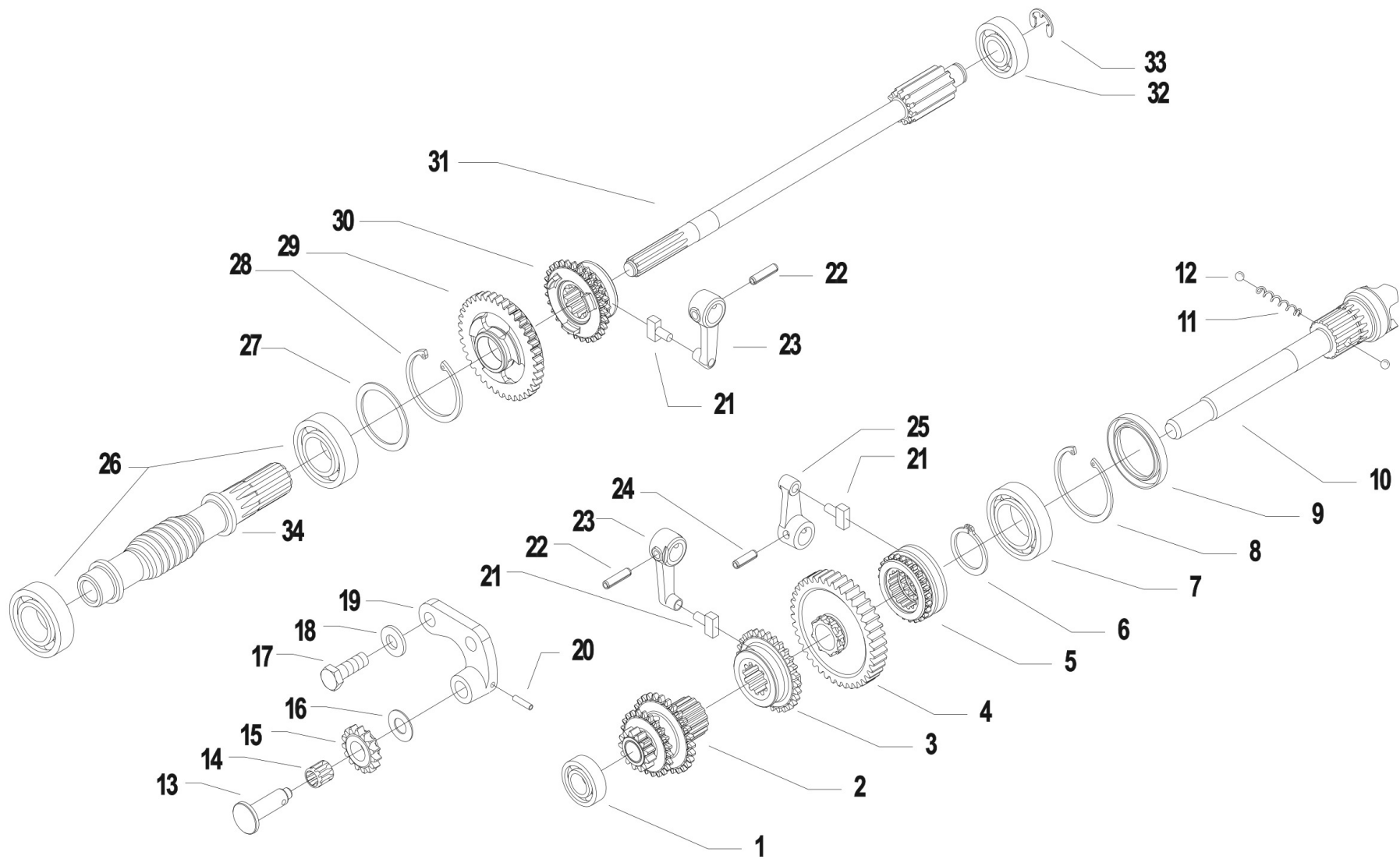

Pos.	Id	Q.ty	Description	Note
1	37111150	1	BEARING 6202 (15X35X11)	
2	59056730	1	TRIPLE GEAR	
3	52456370	1	SLIDER	
4	59056707	1	GEAR	
5	52456706	1	PTO COUPLING	
6	35121031	1	SEEGER RING E 30 UNI 7436	
7	37112229	1	BEARING 6006 (30X55X13) SKF	
8	35111055	1	SEEGER RING I 55 DIN 472	
9	38213800	1	OIL SEAL 38X55X7	
10	52456335	1	PTO SHAFT L=161	
11	58056391	1	SPRING	
12	37910832	1	BALL 1/4	
13	56456736	1	GEAR PIN	
14	37320120	1	ROLLER CAGE 12X15/10	
15	56456347	1	GEAR	
16	56356348	1	ADJUSTING RING	
17	31112211	1	SCREW TE M10X30 UNI 5739	
18	31421101	1	WASHER 10 DIN 679	
19	52456349	1	GEAR SUPPORT	
20	34211042	1	ROLL PIN	
21	58043086	1	SHOE	
22	34213060	1	ROLL PIN	
23	52456389	1	LEVER	
24	34213061	1	ROLL PIN	
25	52456390	1	LEVER	
26	37111255	1	BEARING 6205 (25X52X15)	
27	56356328	1	ADJUSTING RING SP=1,5	
27	56356329	1	ADJUSTING RING SP=1,6	
27	56356330	1	ADJUSTING RING SP=1,7	



Pos.	Id	Q.ty	Description	Note
27	56356331	1	ADJUSTING RING SP=1,8	
28	35111052	1	SEEGER RING I 52 DIN 472	
29	52456732	1	GEAR 1a 3C	
30	52456733	1	SLIDING 3C	
31	52456339	1	SHAFT	
32	37111152	1	BEARING 6302 (15X42X13) SKF	
33	35211120	1	SEEGER RING E 12 UNI 7434	
34	56456475		SCREW 2	



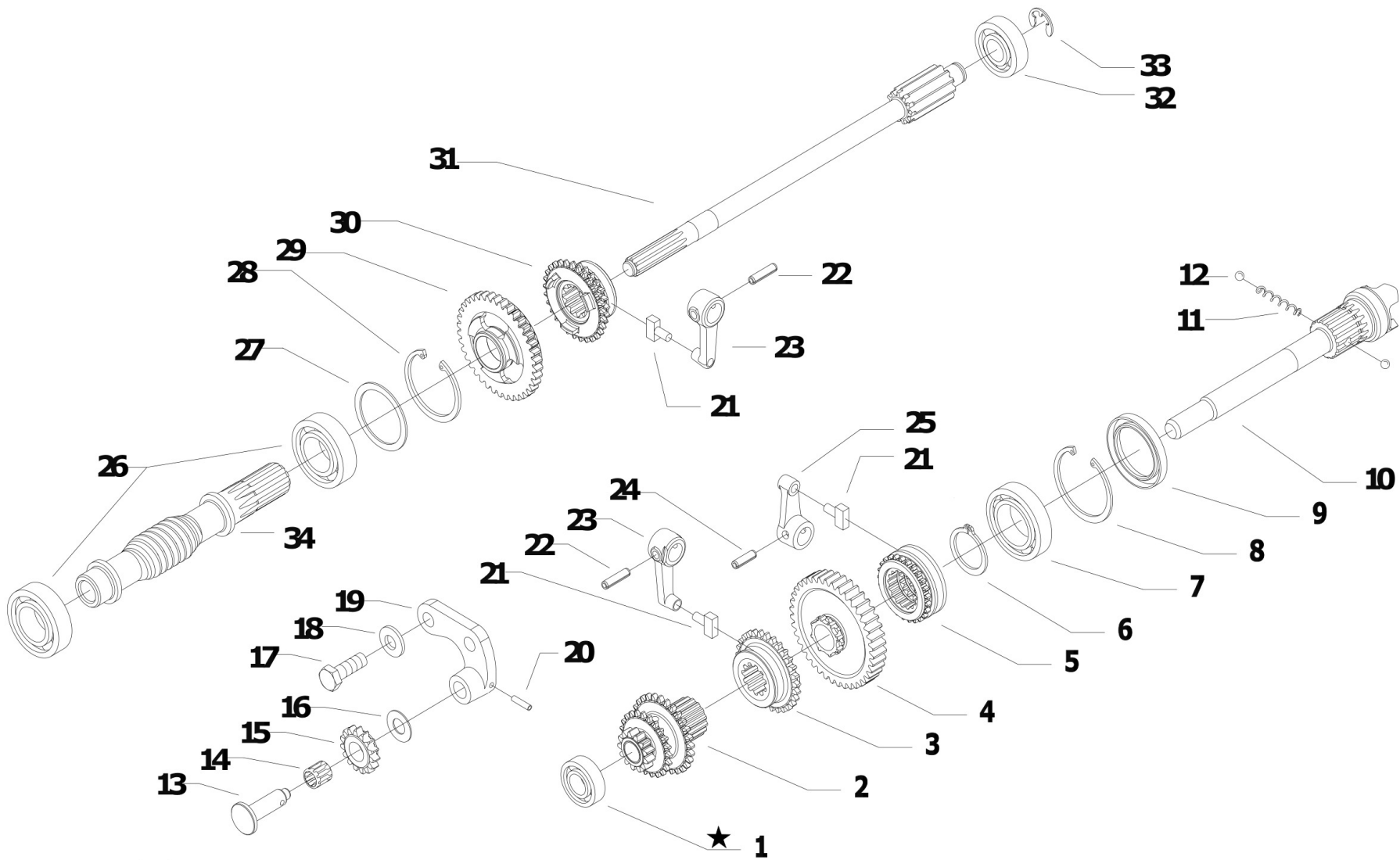

 [Click for info](#)

★ = new part

Pos.	Id	Q.ty	Description	Note
1	37111151	1	BEARING 6202 (15X35X11)	REPLACES 37111150
2	59056730	1	TRIPLE GEAR	
3	52456370	1	SLIDER	
4	59056707	1	GEAR	
5	52456706	1	PTO COUPLING	
6	35121031	1	SEEGER RING E 30 UNI 7436	
7	37112229	1	BEARING 6006 (30X55X13) SKF	
8	35111055	1	SEEGER RING I 55 DIN 472	
9	38213800	1	OIL SEAL 38X55X7	
10	52456335	1	PTO SHAFT L=161	
11	58056391	1	SPRING	
12	37910832	1	BALL 1/4	
13	56456736	1	GEAR PIN	
14	37320120	1	ROLLER CAGE 12X15/10	
15	56456347	1	GEAR	
16	56356348	1	ADJUSTING RING	
17	31112211	1	SCREW TE M10X30 UNI 5739	
18	31421101	1	WASHER 10 DIN 679	
19	52456349	1	GEAR SUPPORT	
20	34211042	1	ROLL PIN	
21	58043086	1	SHOE	
22	34213060	1	ROLL PIN	
23	52456389	1	LEVER	
24	34213061	1	ROLL PIN	
25	52456390	1	LEVER	
26	37111255	1	BEARING 6205 (25X52X15)	
27	56356328	1	ADJUSTING RING SP=1,5	
27	56356329	1	ADJUSTING RING SP=1,6	
27	56356330	1	ADJUSTING RING SP=1,7	



Pos.	Id	Q.ty	Description	Note
27	56356331	1	ADJUSTING RING SP=1,8	
28	35111052	1	SEEGER RING I 52 DIN 472	
29	52456732	1	GEAR 1a 3C	
30	52456733	1	SLIDING 3C	
31	52456339	1	SHAFT	
32	37111152	1	BEARING 6302 (15X42X13) SKF	
33	35211120	1	SEEGER RING E 12 UNI 7434	
34	56456475		SCREW 2	



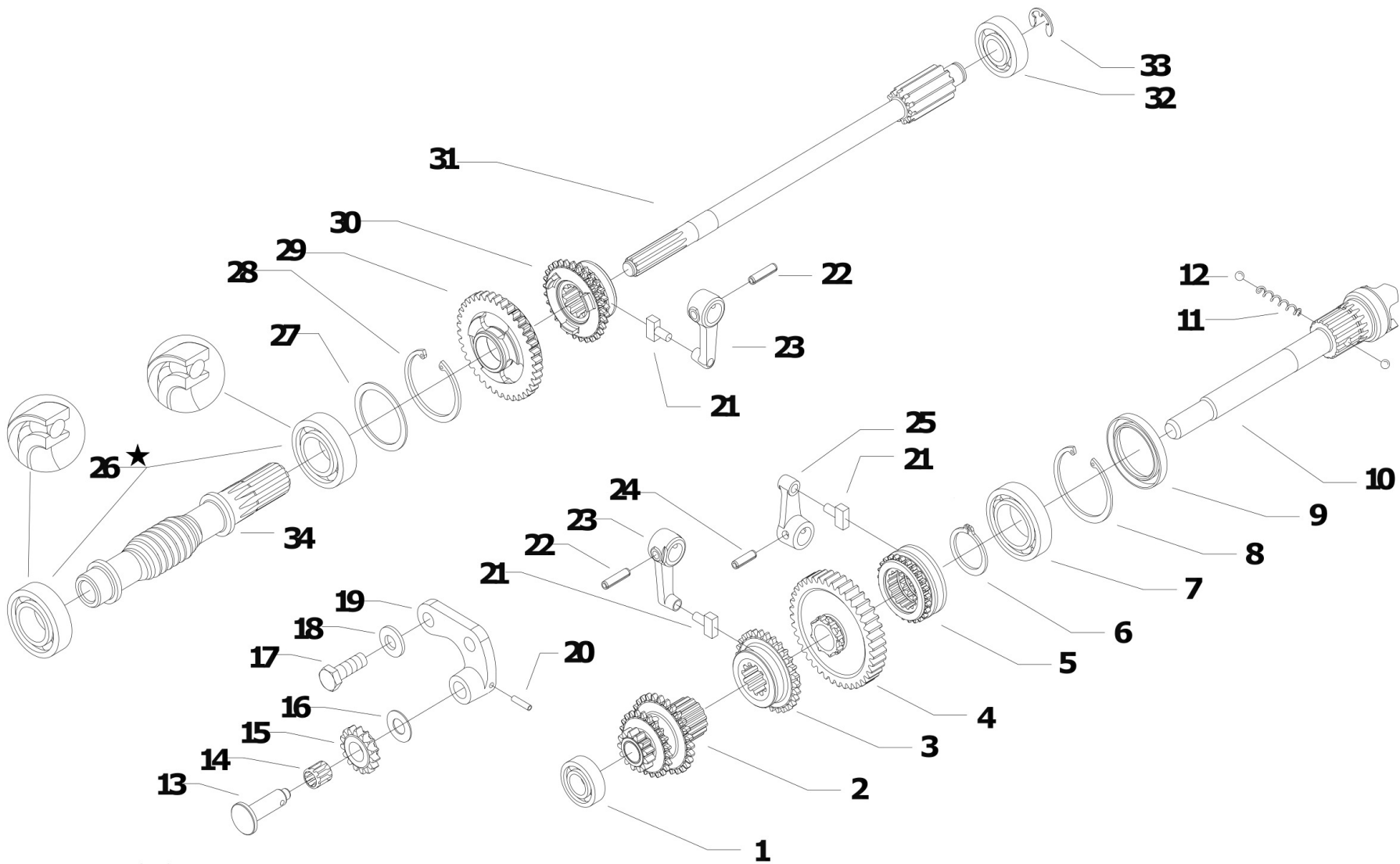

 [Click for info](#)

★ = new part

Pos.	Id	Q.ty	Description	Note
1	37111151	1	BEARING 6202 (15X35X11)	REPLACES 37111150
2	59056730	1	TRIPLE GEAR	
3	52456370	1	SLIDER	
4	59056707	1	GEAR	
5	52456706	1	PTO COUPLING	
6	35121031	1	SEEGER RING E 30 UNI 7436	
7	37112229	1	BEARING 6006 (30X55X13) SKF	
8	35111055	1	SEEGER RING I 55 DIN 472	
9	38213800	1	OIL SEAL 38X55X7	
10	52456335	1	PTO SHAFT L=161	
11	58056391	1	SPRING	
12	37910832	1	BALL 1/4	
13	56456736	1	GEAR PIN	
14	37320120	1	ROLLER CAGE 12X15/10	
15	56456347	1	GEAR	
16	56356348	1	ADJUSTING RING	
17	31112211	1	SCREW TE M10X30 UNI 5739	
18	31421101	1	WASHER 10 DIN 679	
19	52456349	1	GEAR SUPPORT	
20	34211042	1	ROLL PIN	
21	58043086	1	SHOE	
22	34213060	1	ROLL PIN	
23	52456389	1	LEVER	
24	34213061	1	ROLL PIN	
25	52456390	1	LEVER	
26	37141250	1	BEARING 7205-B OBL SKF	REPLACES 37111255
27	56356328	1	ADJUSTING RING SP=1,5	
27	56356329	1	ADJUSTING RING SP=1,6	
27	56356330	1	ADJUSTING RING SP=1,7	



Pos.	Id	Q.ty	Description	Note
27	56356331	1	ADJUSTING RING SP=1,8	
28	35111052	1	SEEGER RING I 52 DIN 472	
29	52456732	1	GEAR 1a 3C	
30	52456733	1	SLIDING 3C	
31	52456339	1	SHAFT	
32	37111152	1	BEARING 6302 (15X42X13) SKF	
33	35211120	1	SEEGER RING E 12 UNI 7434	
34	56456475		SCREW 2	



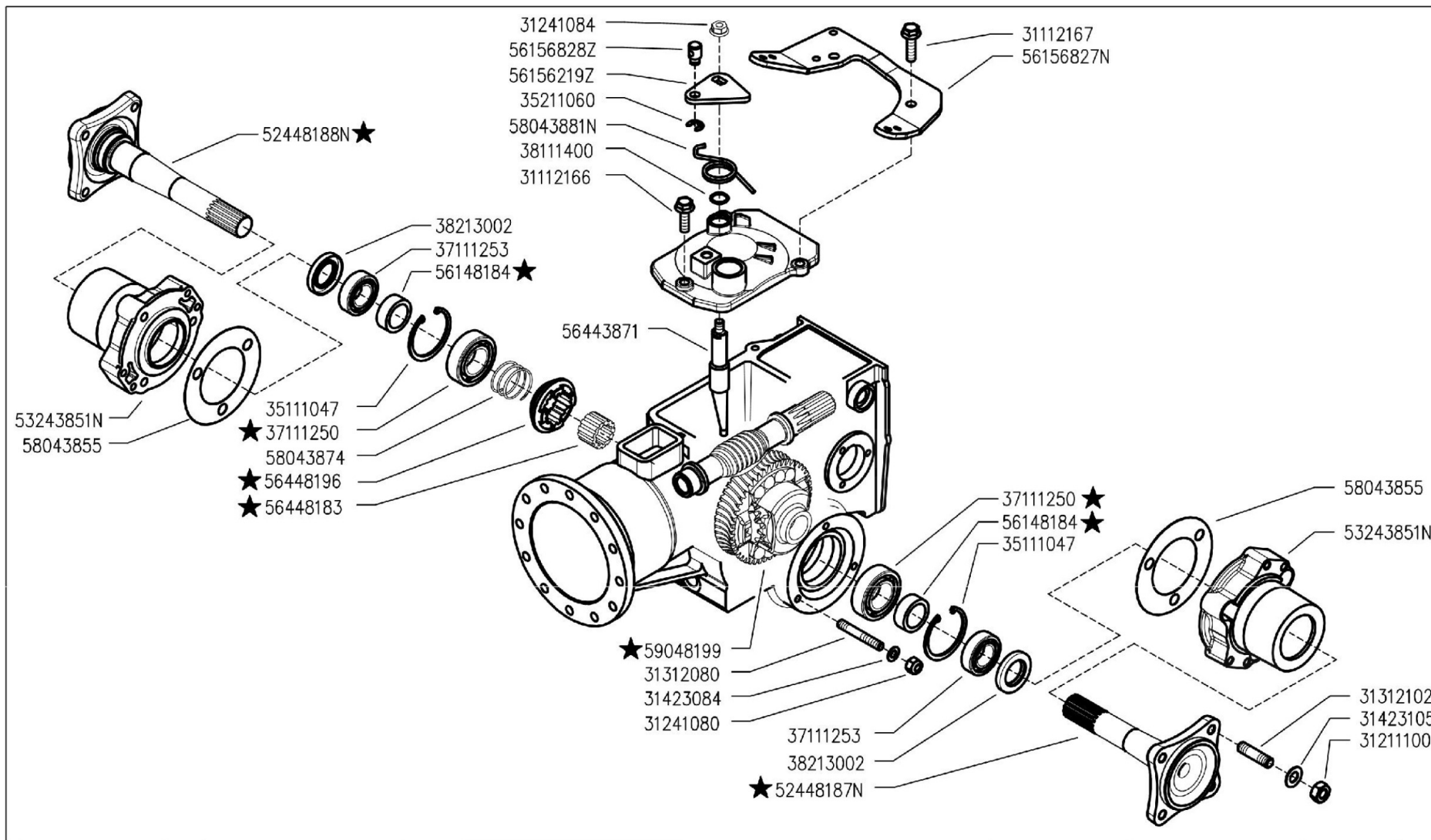

	300 serie PS PowerSafe®	WHEELS AXLE EJE RUEDAS	ASSE RUOTE (330)	ESSIEUS ROUES RÄDACHSE	DALLA MACCHINA DE LA MAQUINA FROM THE MACHINE AB DER MASCHINE ★ N.	_____ _____ _____ _____	I02 01/2010	Rev. 1
						848877	01/2010	

DITE BCS - Scala 1:5



FERRARI Motor mowers, FERRARI 2-wheel tractors - 338 PS

I02_1_67059 - WHEELS AXLE

03/11/2022

Page 52 / 80

Pos.	Id	Q.ty	Description	Note
31112166	31112166	1	SCREW TE C/F M8X25 DIN 6921 8G	
31112167	31112167	1	SCREW TE C/F M8X30 DIN 6921 8G	
31211100	31211100	1	NUT M10	
31241080	31241080	1	HEXAGON SELFLOCK NUT M8	
31241084	31241084	1	SELFLOCK NUT M8 6S	
31312080	31312080	1	STUD BOLT M8X46X20X12	
31312102	31312102	1	STUD BOLT M10X40X24X12	
31423084	31423084	1	SPRING WASHER 8,4	
31423105	31423105	1	SPRING WASHER 10,5	
35111047	35111047	1	SEEGER RING I 47 DIN 472	
35211060	35211060	1	SEEGER RING E 6 UNI 7434	
37111250	37111250	1	BEARING	
37111253	37111253	1	BEARING 6005 (25X47X12)	
38111400	38111400	1	O-RING (14,00X1,78)	
38213002	38213002	1	OIL SEAL 30X40X7	
56148184	56148184	1	RING	
56156827	56156827	1	STOP	
56443871	56443871	1	ROD	
56448183	56448183	1	SPACER	
56448196	56448196	1	COUPLING	
58043855	58043855	1	GASKET	
58043874	58043874	1	SPRING	
59048199	59048199	1	DIFFERENTIAL GEAR	
52448187N	52448187N	1	AXLE SHAFT	
52448188N	52448188N	1	AXLE SHAFT	
53243851N	53243851N	1	HUB	
56156219Z	56156219Z	1	LEVER	
56156828Z	56156828Z	1	STOP	
58043881N	58043881N	1	SPRING	



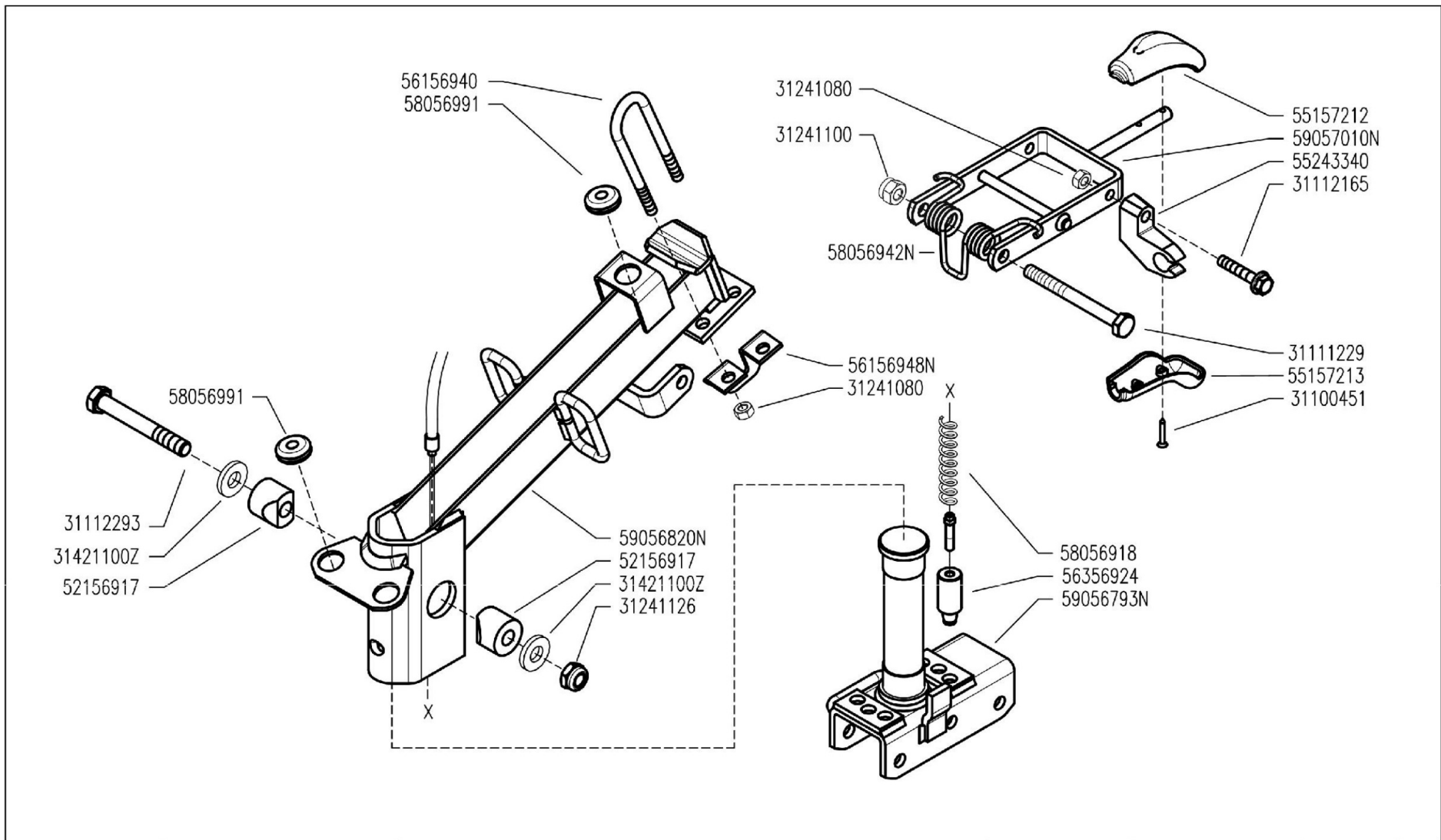

	300 serie PS PowerSafe®	STEERING COLUMN COLUMNA	PIANTONE (320-330)	PLANTON LENKSÄULE	DALLA MACCHINA DE LA MAQUINA FROM THE MACHINE AB DER MASCHINE	N.	Rev.	0
							J02	05/2009

DATE: BCS - Scala 1:4



Pos.	Id	Q.ty	Description	Note
31100451	31100451	1	SCREW 3,5X25	
31111229	31111229	1	SCREW TE M10X110 UNI 5737 8G	
31112165	31112165	1	SCREW TE C/F M8X35 DIN 6921 8G	
31112293	31112293	1	SCREW TE M12X80 UNI 5737	
31241080	31241080	1	HEXAGON SELFLOCK NUT M8	
31241100	31241100	1	SELFLOCK HEXAGON NUT M10	
31241126	31241126	1	SELFLOCK NUT M12	
52156917	52156917	1	WEDGE	
55157212	55157212	1	GRIP	
55157213	55157213	1	GRIP	
55243340	55243340	1	SUPPORT	
56156940	56156940	1	U BOLT	
56356924	56356924	1	FERRULE	
58056918	58056918	1	SPRING	
58056991	58056991	1	CABLE GLAND 90/200/30	
31421100Z	31421100Z	1	CUP SPRING 25X12,2X1,5 D2093	
56156948N	56156948N	1	STOP	
58056942N	58056942N	1	SPRING	
59056793N	59056793N	1	SUPPORT	
59056820N	59056820N	1	COLUMN	
59057010N	59057010N	1	LEVER	



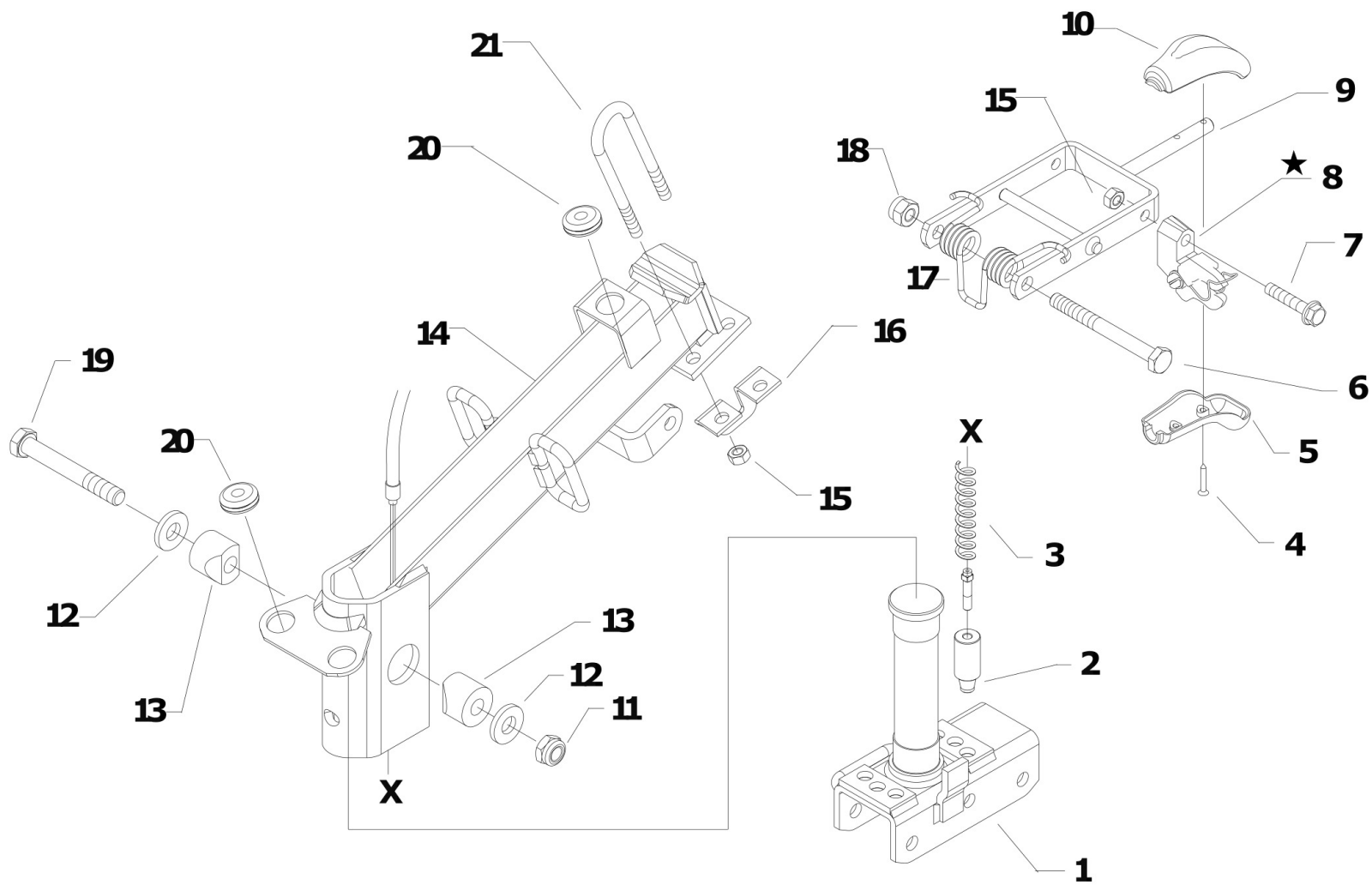

[Click for info](#)

★ = new part

Pos.	Id	Q.ty	Description	Note
1	59056793N		SUPPORT	
2	56356924		FERRULE	
3	58056918		SPRING	
4	31100451		SCREW 3,5X25	
5	55157213		GRIP	
6	31111229		SCREW TE M10X110 UNI 5737 8G	
7	31112165		SCREW TE C/F M8X35 DIN 6921 8G	
8	59243337		ROD SUPPORT WITH SPRING	REPLACES 55243340
9	59057010N		LEVER	
10	55157212		GRIP	
11	31241126		SELFLOCK NUT M12	
12	31421100Z		CUP SPRING 25X12,2X1,5 D2093	
13	52156917		WEDGE	
14	59056820N		COLUMN	
15	31241080		HEXAGON SELFLOCK NUT M8	
16	56156948N		STOP	
17	58056942N		SPRING	
18	31241100		SELFLOCK HEXAGON NUT M10	
19	31112293		SCREW TE M12X80 UNI 5737	
20	58056991		CABLE GLAND 90/200/30	
21	56156940		U BOLT	



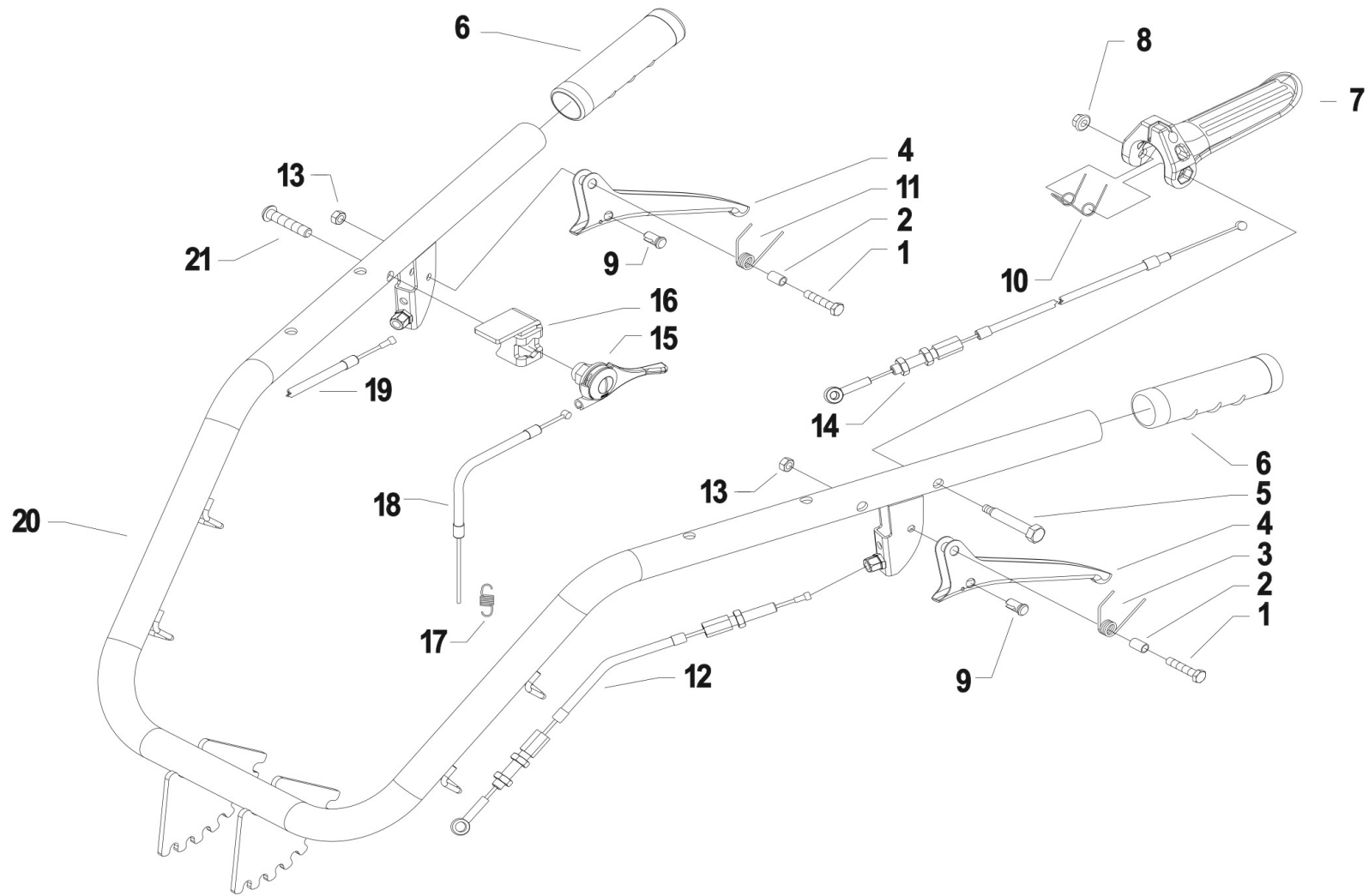

Pos.	Id	Q.ty	Description	Note
1	31112089	1	SCREW TE M6X25 UNI 5739 8G	
2	56156603Z	1	SPACER	
3	58050345	1	SPRING	
4	56148470N	1	LEVER	
5	56356184Z	1	LEVER PIN	
6	58048000	1	KNOB D=27	
7	55256185	1	LEVER	
8	31241065	1	SELFLOCK NUT M6	
9	58150313	1	CABLE CLAMP	
10	58056186Z	1	SPRING	
11	58056593	1	SPRING	
12	58056190	1	LINE L=1460	
13	31241060	1	HEXAGON SELFLOCK NUT M6	
14	58056191	1	LINE L=1560	
15	58002538	1	ACCELERATOR	
16	56156874N	1	PANEL	
17	58056154	1	RESTORING SPRING	For the engine GX200
17	58056155	1	RESTORING SPRING	For the engine GX270
18	58056812	1	LINE AND SHEATH L=1680	L70-L100-15LD350
18	58056815	1	LINE AND SHEATH L=1950	GX200-GX270-GX340-EX21
19	58056193	1	TRANSMISSION	
20	59256175	1	HANDLE BAR	
21	31121020	1	SCREW TBCEI M8X40 ISO7380 10K Z	



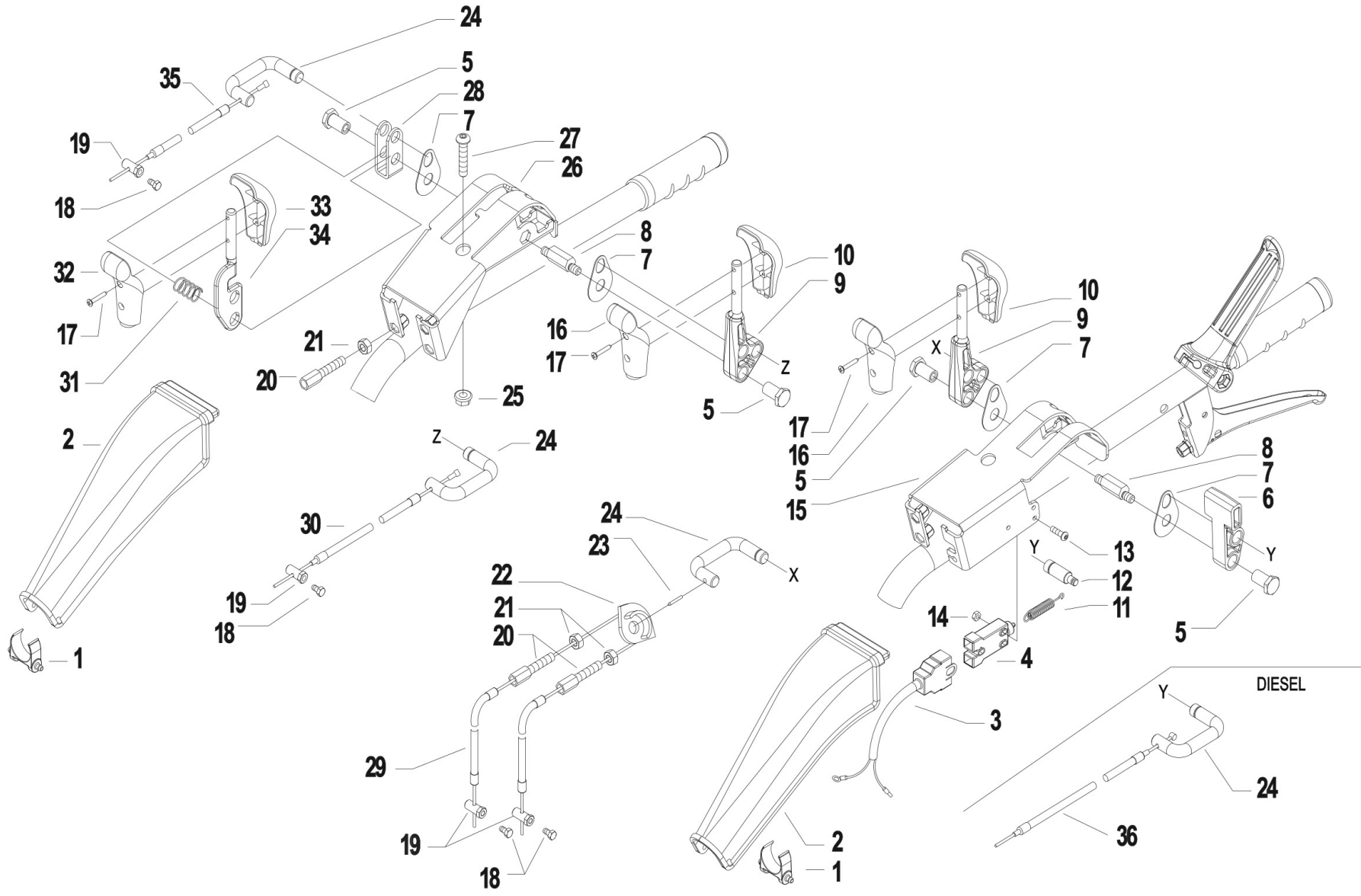

Pos.	Id	Q.ty	Description	Note
1	55256836	1	SUPPORT, ELECTRICAL BOX	
2	55256835	1	PROTECTION COVER	
3	58056837	1	WIRING	
4	58048009	1	ENGINE STOP SWITCH	
5	56148287	1	STUD BOLT	
6	55256197	1	MOTOR STOP LEVER	
7	56356833Z	1	SMALL PLATE	
8	56356858Z	1	PIN	
9	53156860	1	COMMAND LEVER	
10	55157212	1	GRIP	
11	58047712	1	SPRING	
12	56156834Z	1	INDEXING BOLT	
13	31121024	1	SCREW TBCEI FL.M4X25	
14	31241042	1	SELFLOCK NUT M4 FL.6S	
15	59256180	1	SUPPORT	
16	55157213	1	GRIP	
17	31100451	1	SCREW 3,5X25	
18	31112090	1	SCREW TE M6X16 UNI 5739 8G	
19	56356840Z	1	CLAMPING SCREW	
20	58056595	1	ADJUSTING SCREW M8	
21	31211080	1	NUT M8	
22	55256757	1	PULLEY	
23	34213020	1	ROLL PIN	
24	56156832Z	1	U BOLT	
25	31241084	1	SELFLOCK NUT M8 6S	
26	59256850	1	SUPPORT	
27	31121020	1	SCREW TBCEI M8X40 ISO7380 10K Z	
28	56156859Z	1	FORK	
29	58056841	1	LINE AND SHEATH L=1300	For models 346/360 PS Series



Pos.	Id	Q.ty	Description	Note
29	58056845	1	LINE AND SHEATH L=1200	For the 340 model series PS
29	58056849	1	LINE AND SHEATH L=1080	For models 330/338 PS Series
30	58056847	1	LINE AND SHEATH L=1100	For models 340/346/360 PS Series
30	58056848	1	LINE AND SHEATH L=930	For models 330/338 PS Series
31	58049830	1	SPRING	
32	55157215	1	GRIP	
33	55157214	1	GRIP	
34	52156810Z	1	COMMAND LEVER	
35	58056846	1	LINE AND SHEATH L=1190	For models 340/346/360 PS Series
35	58056848	1	LINE AND SHEATH L=930	For models 330/338 PS Series
36	58049501	1	LINE AND SHEATH (L=1790)	For model series 340 PS engine with L100
36	58049505	1	LINE AND SHEATH (L=1610)	For models 330/338 series engines with PS L70/L100/15LD350
36	58056814	1	LINE AND SHEATH L=1610	For models 340/360 series PS engine 15LD440. For model series 346 PS with engine15LD500
36	58057337	1	LINE AND SHEATH (L=1680)	For Model 360 series PS engine 3LD510



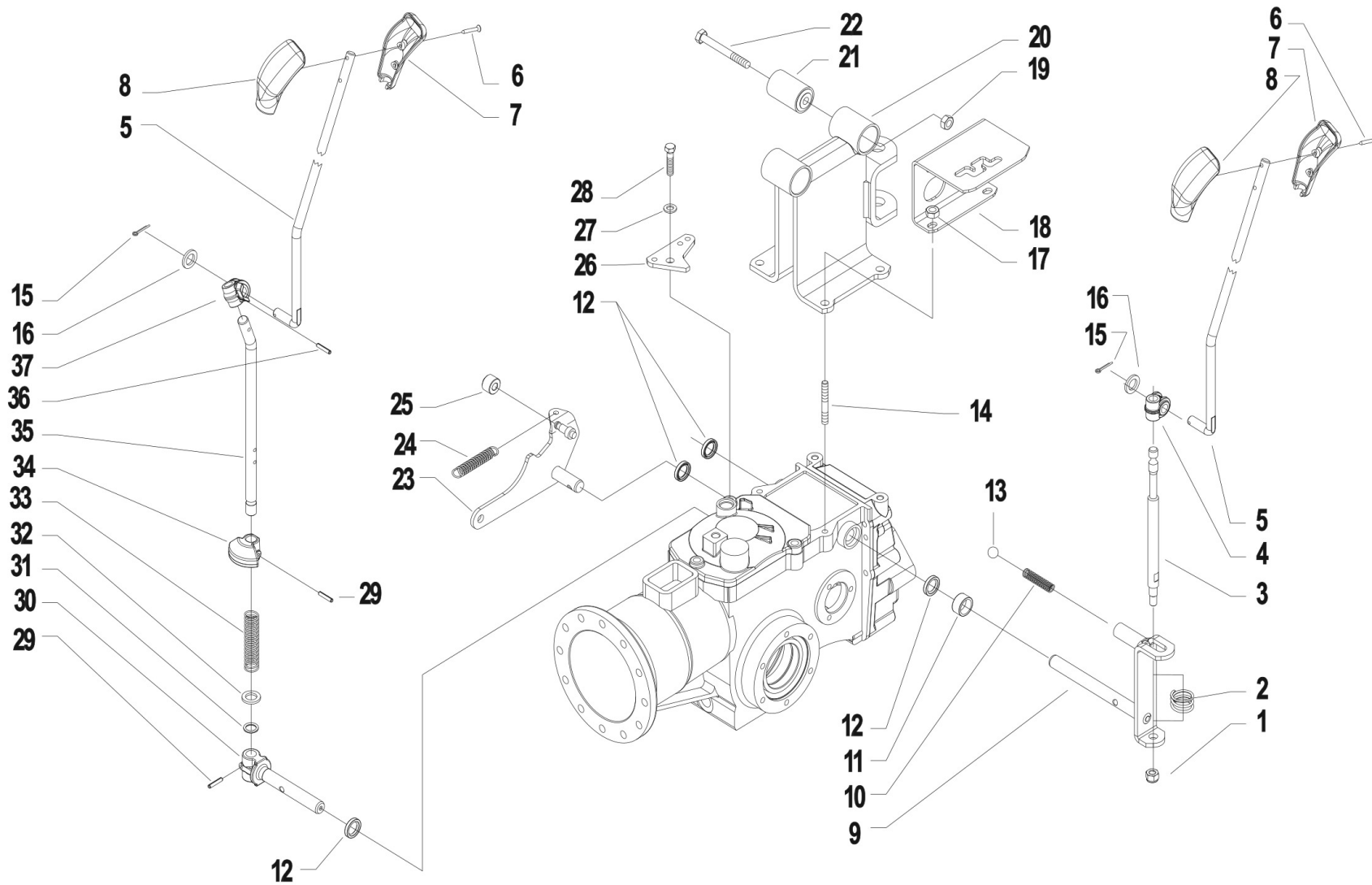

Pos.	Id	Q.ty	Description	Note
1	31241080	1	HEXAGON SELFLOCK NUT M8	
2	58057232Z	1	SPRING	
3	56356738Z	1	COMMAND LEVER	
4	55242528	1	JOINT	
5	56156792N	1	PULL ROD 2+2 ED	
6	31100451	1	SCREW 3,5X25	
7	55157213	1	GRIP	
8	55157212	1	GRIP	
9	59056735N	1	GEAR LEVER	
10	58043176	1	SPRING	
11	56157257Z	1	SPACER	
12	38211400	1	OIL SEAL 14X22X4	
13	37911532	1	BALL 15/32	
14	31312082	1	STUD BOLT M8X38X14X20	
15	34110028	1	SPLIT PIN A3X15 UNI 1336	
16	31411104	1	WASHER 10,5x18	
17	31241084	1	SELFLOCK NUT M8 6S	
18	56156734H	1	SELECTOR	
19	31241100	1	SELFLOCK HEXAGON NUT M10	
20	59056920	1	SUPPORT	
21	30010142	1	SILENT-BLOCK 10,2X30X45X49	
22	31111217	1	SCREW TE M10X75 UNI 5737 8G	
23	59057319	1	LEVER	
24	58057273	1	SPRING	
25	55257313	1	ROLLER	
26	56157274	1	SQUARE	
27	31423084	1	SPRING WASHER 8,4	
28	31112152	1	SCREW TE M8X30 UNI 5739 8G	
29	34213020	1	ROLL PIN	



Pos.	Id	Q.ty	Description	Note
30	52357250	1	PIN	
31	38111191	1	O-RING 115 (11,91X2,62)	
32	31414130	1	WASHER 13	
33	F0831193010	1	SPRING DM.15X70	
34	55257321	1	STOP	
35	56157324N	1	PTO LEVER	
36	34213024	1	ROLL PIN	
37	55248379	1	PTO JOINT	



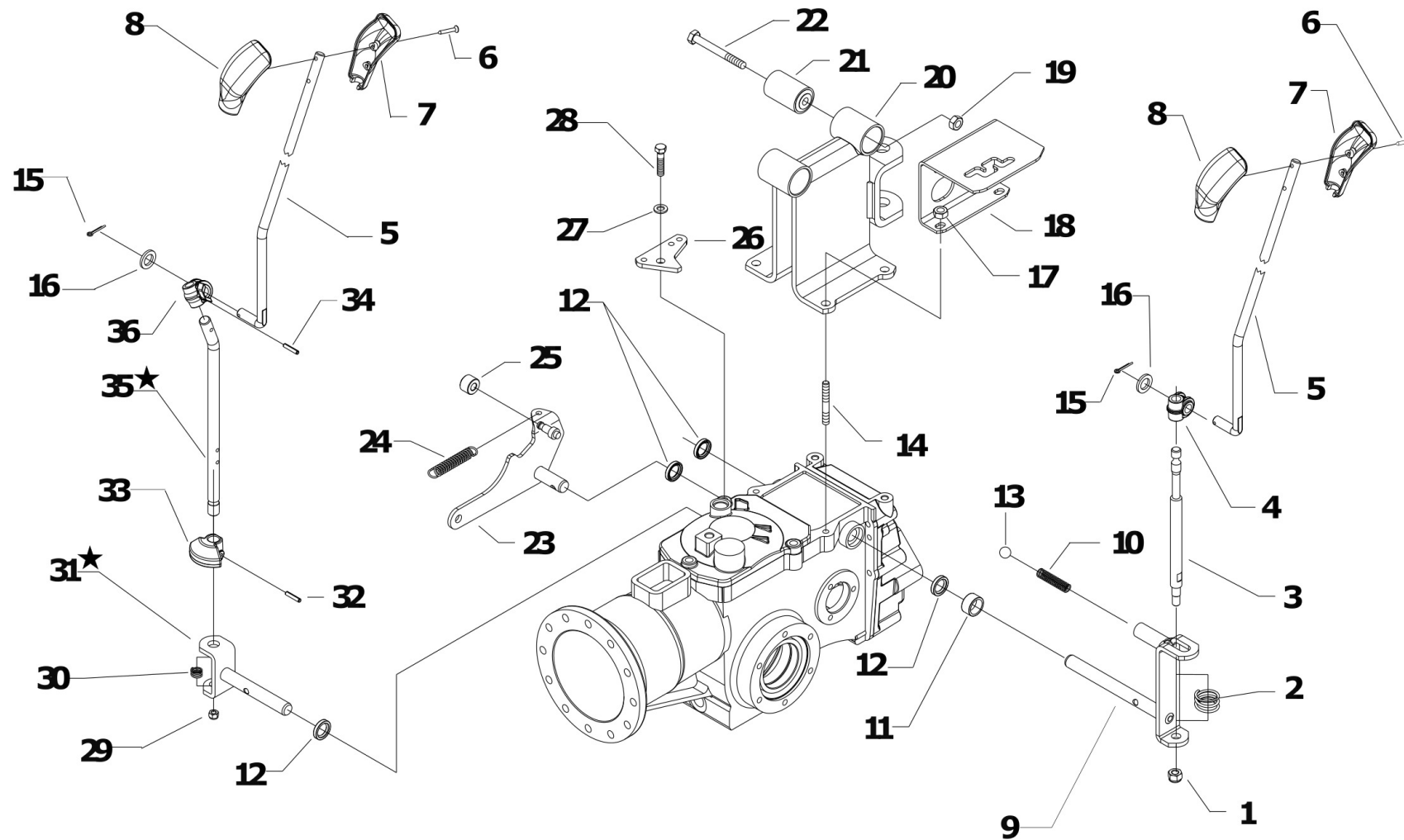

[Click for info](#)

★ = new part

Pos.	Id	Q.ty	Description	Note
1	31241080		HEXAGON SELFLOCK NUT M8	
2	58057232Z		SPRING	
3	56356738Z		COMMAND LEVER	
4	55242528		JOINT	
5	56156792N		PULL ROD 2+2 ED	
6	31100451		SCREW 3,5X25	
7	55157213		GRIP	
8	55157212		GRIP	
9	59056735Z		GEARBOX COMPLETE LEVER	
10	58043176		SPRING	
11	56157257Z		SPACER	
12	38211400		OIL SEAL 14X22X4	
13	37911532		BALL 15/32	
14	31312082		STUD BOLT M8X38X14X20	
15	34110028		SPLIT PIN A3X15 UNI 1336	
16	31411104		WASHER 10,5x18	
17	31241084		SELFLOCK NUT M8 6S	
18	56156734H		SELECTOR	
19	31241100		SELFLOCK HEXAGON NUT M10	
20	59056920		SUPPORT	
21	30010142		SILENT-BLOCK 10,2X30X45X49	
22	31111217		SCREW TE M10X75 UNI 5737 8G	
23	59057319		LEVER	
24	58057273		SPRING	
25	55257313		ROLLER	
26	56157274		SQUARE	
27	31423084		SPRING WASHER 8,4	
28	31112152		SCREW TE M8X30 UNI 5739 8G	
29	31241080		HEXAGON SELFLOCK NUT M8	



Pos.	Id	Q.ty	Description	Note
30	58057232Z		SPRING	
31	590C1040Z		COMPLETE PTO LEVER GALV.	REPLACES 52357250 + 56157324N
32	34213020		ROLL PIN	
33	55257321		STOP	
34	34213024		ROLL PIN	
35	561C1043Z		LONG PDF LEVER	REPLACES 52357250 + 56157324N
36	55248379		PTO JOINT	



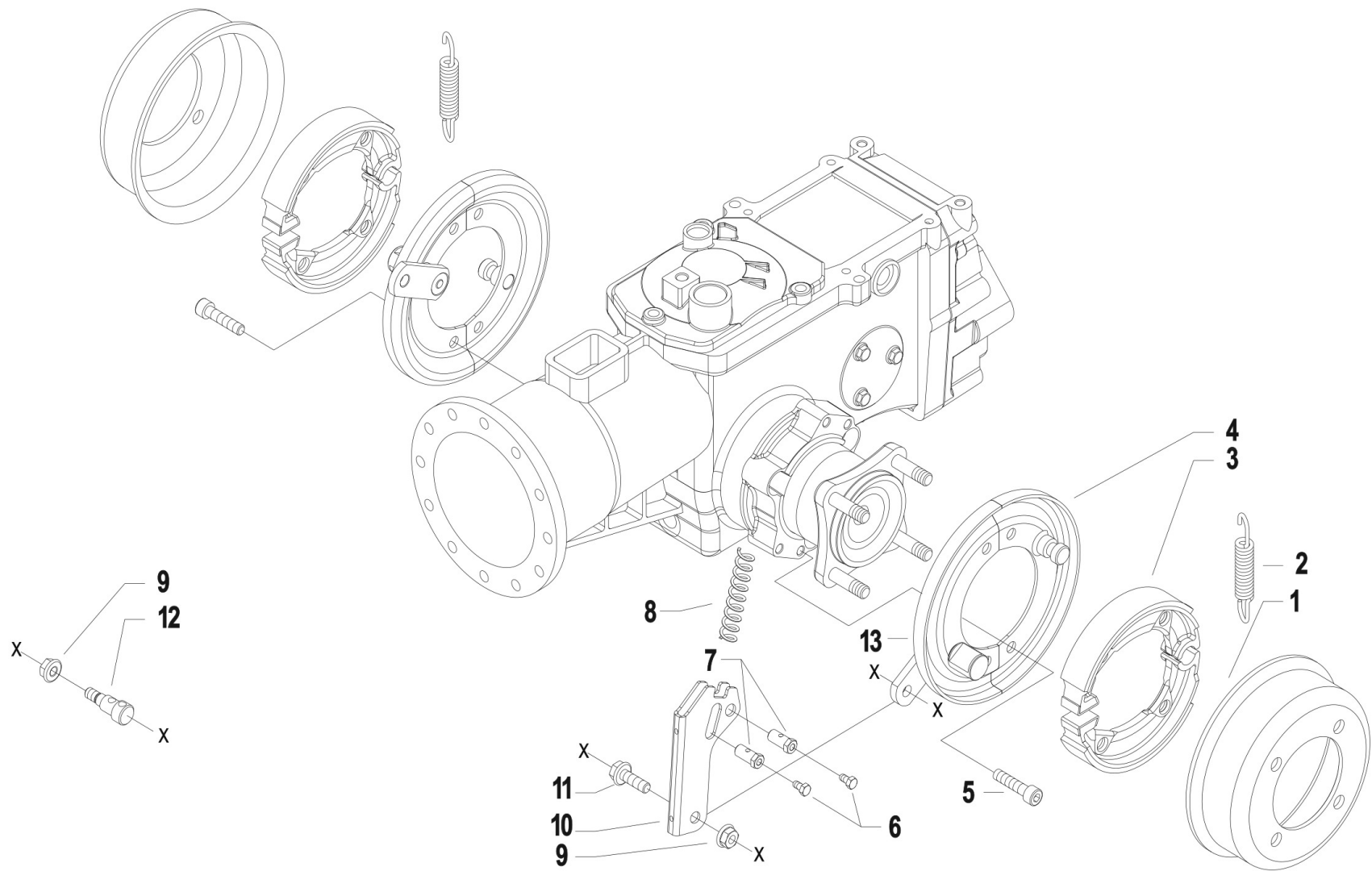

Pos.	Id	Q.ty	Description	Note
1	56148218N	1	BRAKE DRUM	
2	58048215	1	SPRING	
3	58048214	1	BRAKE BLOCK	
4	59048208N	1	HALF DISC	
5	31152085	1	SCREW TCEI M8X25 UNI 5931	
6	31112090	1	SCREW TE M6X16 UNI 5739 8G	Used in the models 330/338/340 PS Series
7	56356840	1	CLAMPING SCREW	Used in the models 330/338/340 PS Series
8	58056918	1	SPRING	
9	31241084	1	SELFLOCK NUT M8 6S	
10	56156831Z	1	FORK	Used in the models 330/338/340 PS Series
11	31112166	1	SCREW TE C/F M8X25 DIN 6921 8G	Used in the models 330/338/340 PS Series
12	56356857Z	1	STOP	Used in the models 346/360 PS Series
13	59048200N	1	HALF DISC	



	A	B	C	D
4.00 - 8"	39114008	39414008	58043250 0	92480719 (kg.11)
4.0 - 10"	39114010	39415010 0	58048330 0	92480720 (kg.15)
5.0 - 10"	39115010	39415010	58048330 0	92480720 (kg.15)
5.00 - 12"	39115012	39415012	58044804 0	92480721 (kg.34)
6.5/80 - 12"	39116018	39416018	58044804 0	92480721 (kg.34)
6.5/80 - 15"	39116020	39416020	58042746 0	92480721 (kg.34)

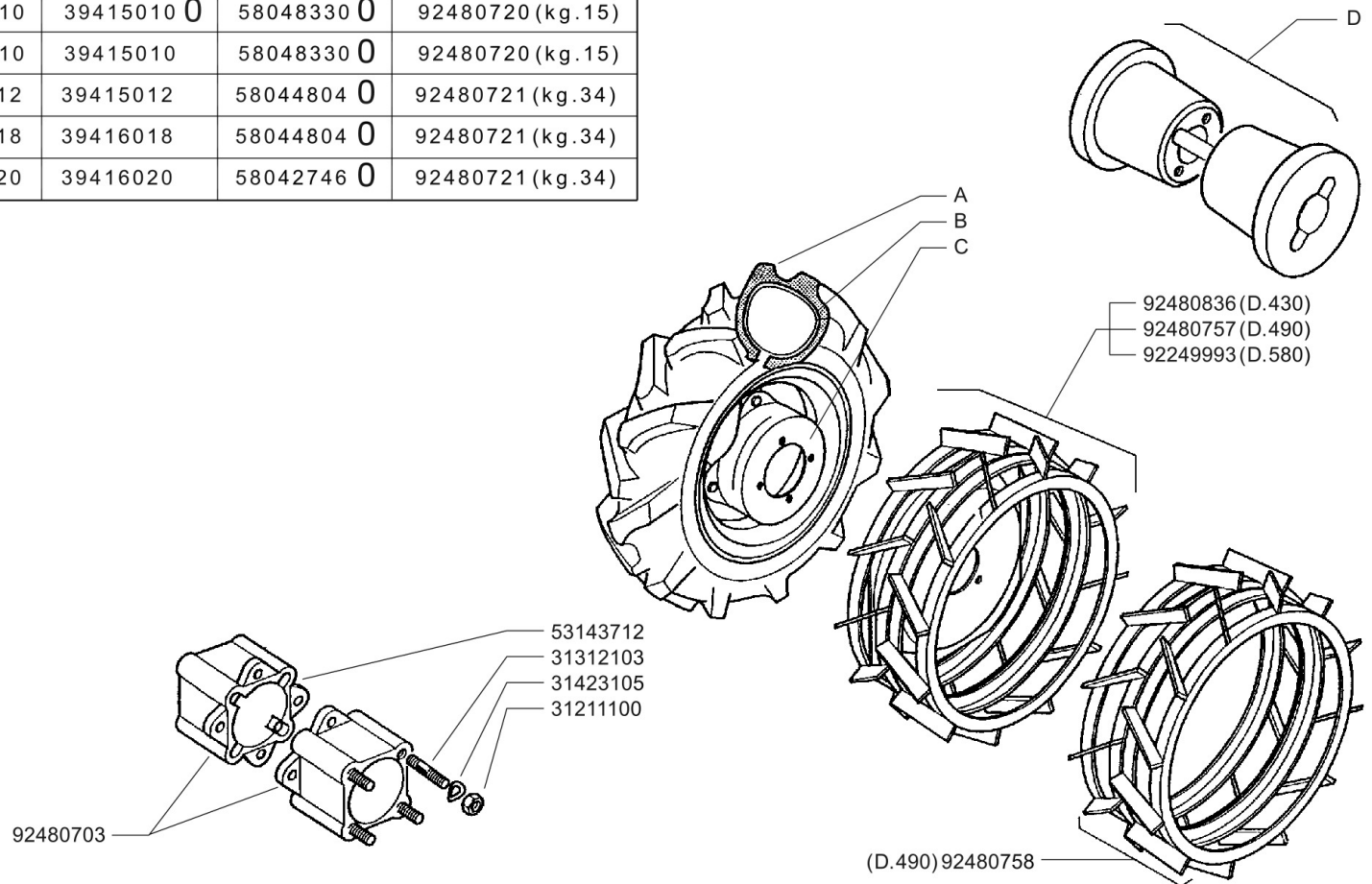

FERRARI

300 serie PS
PowerSafe®

RUOTE

WHEELS
RUEDAS

ROUES
RÄDER

DALLA MACCHINA
FROM THE MACHINE
DE LA MACHINE
DE LA MAQUINA
AB DER MASCHINE

ON.

AGGIORNAMENTO
REVISION
MISE A JOUR
APLAZAMIENTO
ANPASSUNG

P01

11/2010

Rev. **1**

ZEVE

Pos.	Id	Q.ty	Description	Note
31211100	31211100	1	NUT M10	
31312103	31312103	1	STUD BOLT M10X46X24X16	
31423105	31423105	1	SPRING WASHER 10,5	
39114008	39114008	1	TYRE 4.00-8 2PR	
39114010	39114010	1	TYRE 4.0-10 2PR	
39115010	39115010	1	TYRE 5.00-10 2PR	
39115012	39115012	1	TYRE 5.00-12 2PR	
39116018	39116018	1	TYRE 6.5/80-12 2PR	
39116020	39116020	1	TYRE 6.5/80-15 4PR	
39414008	39414008	1	INNER TUBE X 4.00-8	
39414010	39414010	1	INNER TUBE x 4.0-10	
39415010	39415010	1	INNER TUBE X 4.0/5.0-10	
39415012	39415012	1	INNER TUBE	
39416018	39416018	1	INNER TUBE X 6-5/80-12	
39416020	39416020	1	INNER TUBE X 6.5/80-15	
53143712	53143712	1	SPACER	
58042746	58042746	1	RIM 5J15 CR	
58043250	58043250	1	RIM 2.50-8	
58044804	58044804	1	RIM 5JA12	
58048330	58048330	1	RIM 3.50D10 CR	
58052332	58052332	1	RIM 5J15 CR	
92249993	92249993	1	STEEL CAGE WHEELS D. 58 (PAIR)	
92480703	92480703	1	SPACER CM. 6 FOR WHEELS (PAIR)(0901012301)	
92480719	92480719	1	WEIGHTS KG. 11 FOR WHEELS 4.00-8 FOR 305/306 (PAIR)	
92480720	92480720	1	WEIGHTS KG. 15 FOR WHEELS 4.0-10 AND 5.0-10 FOR 305/306/307 (PAIR)	
92480721	92480721	1	WEIGHTS KG. 34 FOR WHEELS 5.00-12 / 6.5/80-12 (PAIR) (0901012307)	
92480757	92480757	1	CAGE WHEELS DIAM. CM. 49 FOR 306/30 (PAIR) (0901012315)	
92480758	92480758	1	ADAPTER RINGS FOR MOUNTING STEEL CAGE WHEELS CM. 49 (PAIR)	
92480836	92480836	1	STEEL CAGE WHEELS DIAM. 43 CM.	



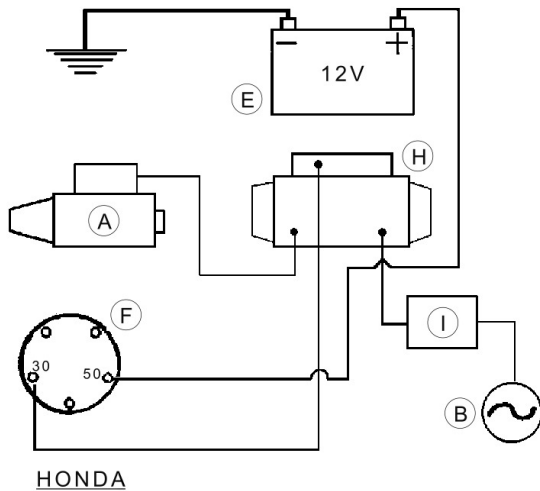

HONDA

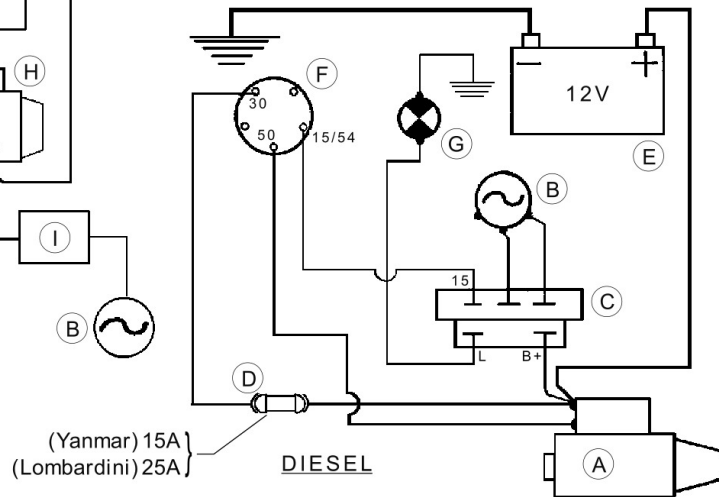

(Yanmar) 15A
(Lombardini) 25A

DIESEL

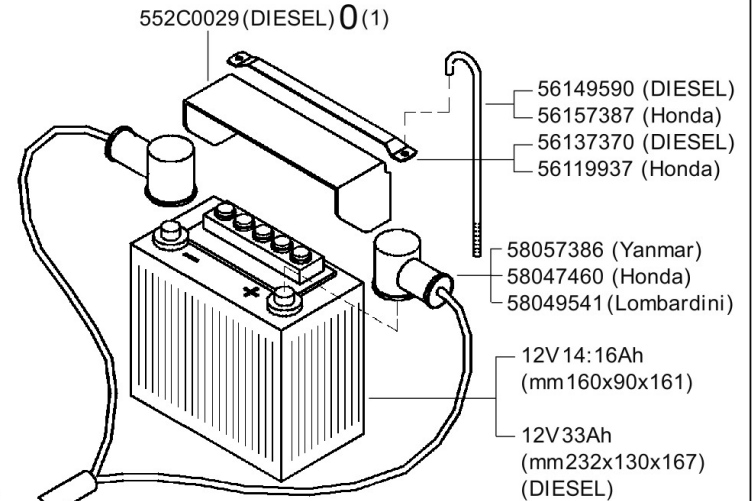

56149590 (DIESEL)
56157387 (Honda)
56137370 (DIESEL)
56119937 (Honda)

58057386 (Yanmar)
58047460 (Honda)
58049541 (Lombardini)

12V 14:16Ah
(mm 160x90x161)

12V 33Ah
(mm 232x130x167)
(DIESEL)

A	B	C	D
MOTORINOD'AVVIAMENTO STARTER DÉMARREUR MOT. DE ARRANQUE ANLASSMOTOR	GENERATORE GENERATOR GÉNÉRATEUR GENERADOR GENERATOR	REGOLATORE REGULATOR RÉGULATEUR REGULADOR REGLER	FUSIBILI FUSES FUSIBLES FUSIBLES SCHMELZSICHERUNGEN

E	F	G	H	I
BATTERIA BATTERY BATTERIE BATERIA BATTERIE	INTERRUTTORE SWITCH INTERRUPTEUR INTERRUPTOR SCHALTER	SPIA CARICA BATTERIA BATTERY LONG WARN. LIGHT TEMOIN CHARG. BATTERIE LUZ CARGA BATERIA BATTERIE LADUNGKTRL. LAMPE	SOLENOIDE SOLENOID SOLÉNOÏDE SOLENOIDE SOLENOID	DIODO DIODE DIODE DIODE DIODE

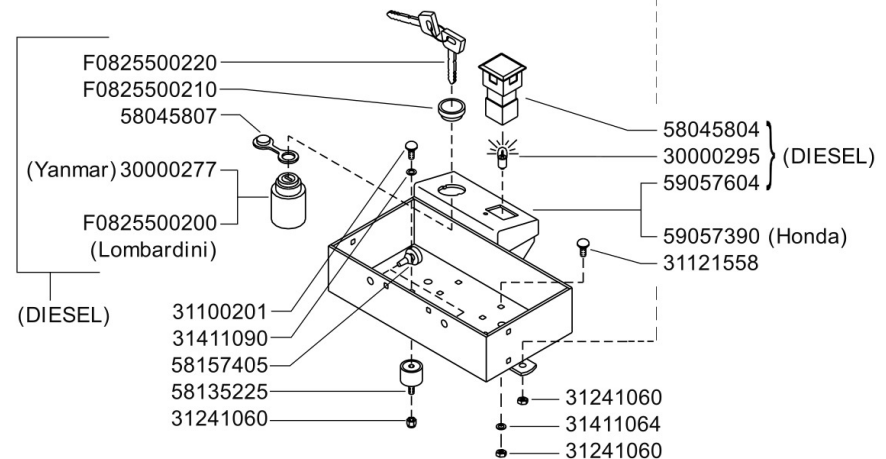

F0825500220
F0825500210
58045807
(Yanmar) 30000277
F0825500200
(Lombardini)
(DIESEL)

58045804
30000295
59057604 } (DIESEL)
59057390 (Honda)
31121558

31100201
31411090
58157405
58135225
31241060
31241060
31241060

(1) sostituisce **58057610**

FERRARI

300 serie **PS**
PowerSafe®

AVVIAMENTO ELETTRICO

ELECTRIC STARTER
ARRANQUE ELECTRICO

DÉMARRAGE ELECTRIQUE
ELEKTROSTART

DALLA MACCHINA
FROM THE MACHINE
DE LA MACHINE
DE LA MAQUINA
AB DER MASCHINE

0 N.

884219

Q01 1

05/2011

Rev.
1
ZENE

Pos.	Id	Q.ty	Description	Note
30000277	30000277	1	SWITCH	
30000295	30000295	1	LAMP 12V-5W-W2,1X9,5D	
31100201	31100201	1	SCREW TTQ M6X12 UNI 5731	
31121558	31121558		SCREW TTQ M6X16 UNI 5731	
31241060	31241060	1	HEXAGON SELFLOCK NUT M6	
31411064	31411064	1	WASHER 6,4x12,5	
31411090	31411090	1	WASHER 9x24	
552C0029	552C0029	1	COVER	
56119937	56119937	1	BATTERY SUPPORT	
56137370	56137370	1	BATTERY BRACKET	
56149590	56149590	1	BATTERY BRACKET	
56157387	56157387	1	ROD	
58045804	58045804	1	WARNING LIGHT	
58045807	58045807	1	LOCK COVER	
58047460	58047460	1	WIRING	
58049541	58049541	1	WIRING	
58057386	58057386	1	WIRING	
58135225	58135225		VIBRATION-DAMPING	
58157405	58157405	1	PLUG	
59057390	59057390	1	BOX	
59057604	59057604	1	BOX	
F0825500200	F0825500200	1	CHANGE-OVER SWITCH	
F0825500210	F0825500210	1	RING NUT	
F0825500220	F0825500220	1	KEY	



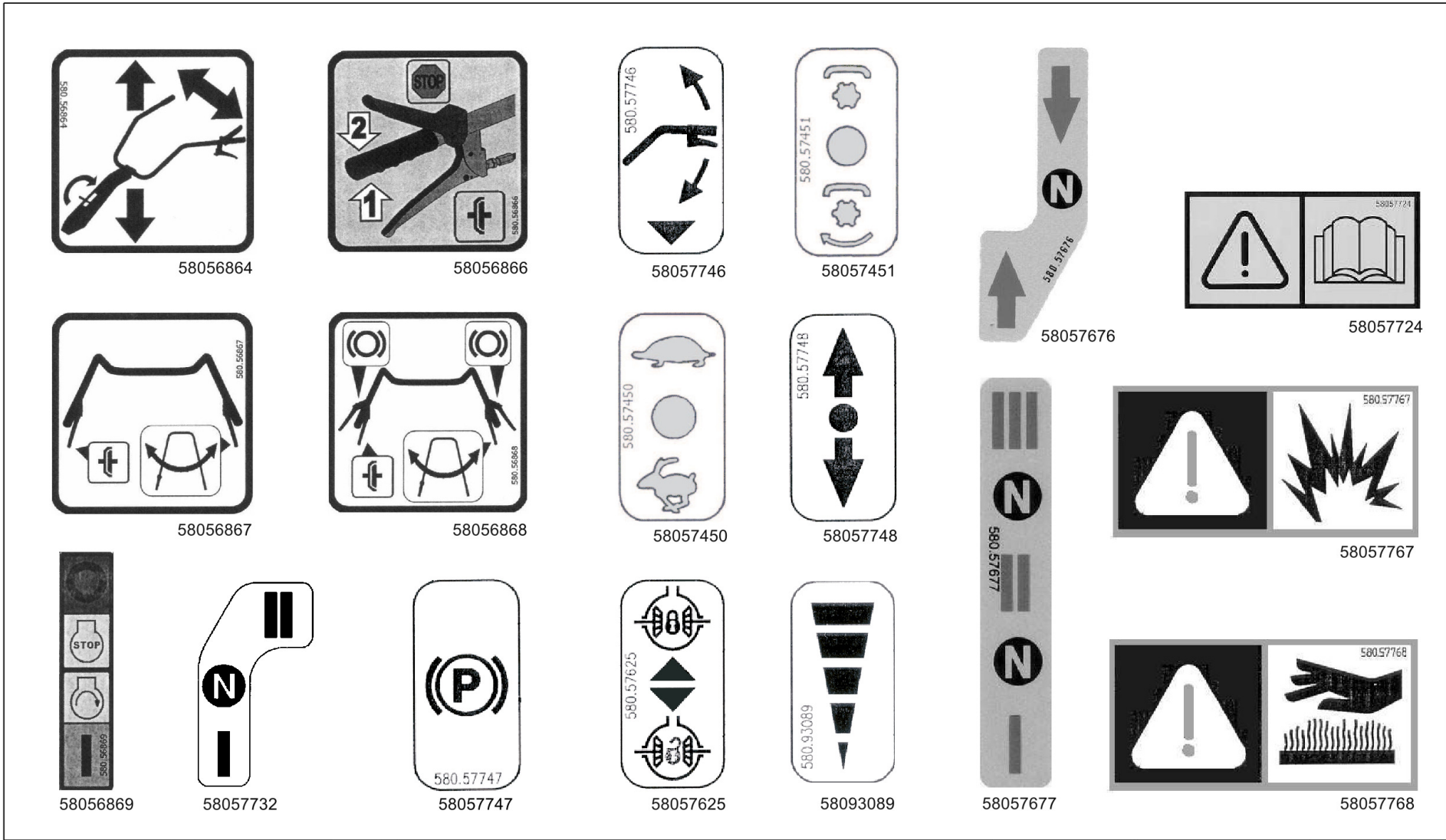

FERRARI

300 serie **PS**
PowerSafe®

STICKERS
ADHESIVOS

ADESME

AUTOCOLLANTS
AUFKLEBES

DALLA MACCHINA
FROM THE MACHINE
DE LA MACHINE
DE LA MAQUINA
AB DER MASCHINE

N.

Rev.
R01 0

05/2009

ZEVE

Pos.	Id	Q.ty	Description	Note
58056864	58056864	1	DECAL	
58056866	58056866	1	DECAL	
58056867	58056867	1	DECAL	
58056868	58056868	1	DECAL	
58056869	58056869	1	DECAL	
58057450	58057450	1	DECAL	
58057451	58057451	1	DECAL	
58057625	58057625	1	DECAL	
58057676	58057676	1	DECAL	
58057677	58057677	1	DECAL	
58057724	58057724	1	DECAL	
58057732	58057732	1	DECAL	
58057746	58057746	1	DECAL	
58057747	58057747	1	DECAL	
58057748	58057748	1	DECAL	
58057767	58057767	1	DECAL	
58057768	58057768	1	DECAL	
58093089	58093089	1	DECAL	



PowerSafe®

1



6



7

EasyDrive®

2



8



9



3

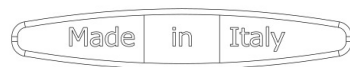

4



10



11



5



12



13

Pos.	Id	Q.ty	Description	Note
1	53057666	1	POWERSAFE BRAND	
2	53057670	1	DECAL	
3	53052175	1	MEDIUM FERRARI BRAND	
4	530C0056	1	DECAL MADE IN ITALY	
5	53052176	1	BIG FERRARI BRAND	
6	58052178	1	DECAL 310 /11	
7	58052179	1	DECAL 320 /11	
8	58052193	1	DECAL 328 /11	
9	58052180	1	DECAL 330 /11	
10	58052192	1	DECAL 338 /11	
11	58052181	1	DECAL 340 /11	
12	58052182	1	DECAL 346 /11	
13	58052191	1	DECAL 360 /11	



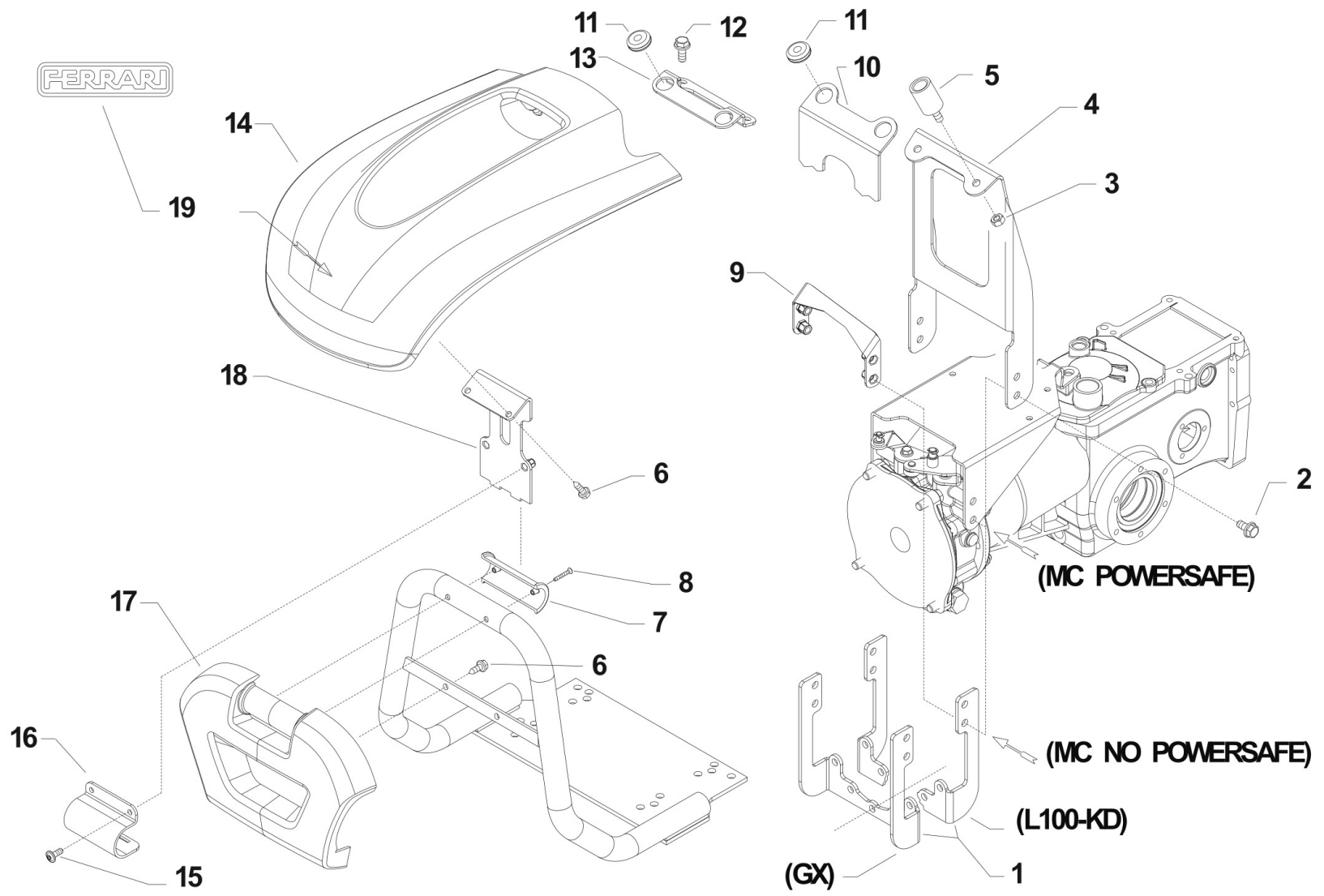

i = info - stop 2 sec. ★ = new part



Pos.	Id	Q.ty	Description	Note
1	56157515N		HOLDER	
2	31112170		SCREW TE C/F M8X20 DIN 6921	
3	31211080		NUT M8	
4	56157498N		SUPPORT	KD440
4	56157499N		SUPPORT	KD350 - GX340 - GX390 - POWERSAFE
4	56157513N		SUPPORT	GX270
4	56157516N		SUPPORT	L100
5	58042111		STOPPER	
6	31510100		RIBBED SCREW 6,3X19 UNI 6950	
7	55252504		HALF BEARING	
8	31100451		SCREW 3,5X25	
9	59257488		SUPPORT	NO POWERSAFE SERIES
10	56157495N		SUPPORT	KD350
11	58056991		CABLE GLAND 90/200/30	
12	31112171		SCREW TE C/F M8X16 DIN 6921	3LD510
13	561C0078N		REAR SUPPORT	3LD510
14	55252502		BONNET	
15	31121018		SCREW TBCEI FLANG. M6X16	
16	56157519N		RH HINGE	
17	55252503		FREGIO ANT.MC 2010 FERRARI	
18	59257517		PLATE	KD440 - L100
18	59257523		PLATE	KD350 - GX
18	592C0080		PLATE	
19	53052175		MEDIUM FERRARI BRAND	

